



Filter Radiometers for Weathering and Photo Stability Tests

Artur Schönlein
ATLAS Material Testing Technology GmbH
Vogelsbergstr. 22, 63589 Linsengericht-Altenhaslau
Germany



Experience.
The Atlas Difference.



Contents



- Introduction
- Spectral Energy Distribution
- Selective Filter Radiometers
 - Design and Characteristics
 - Calibration of the Selective Filter Radiometers
 - Xenon Lampe as a Reference Standard
- Spectral Correction Factor
- Sources of Errors in UV Radiation Measurements



Introduction

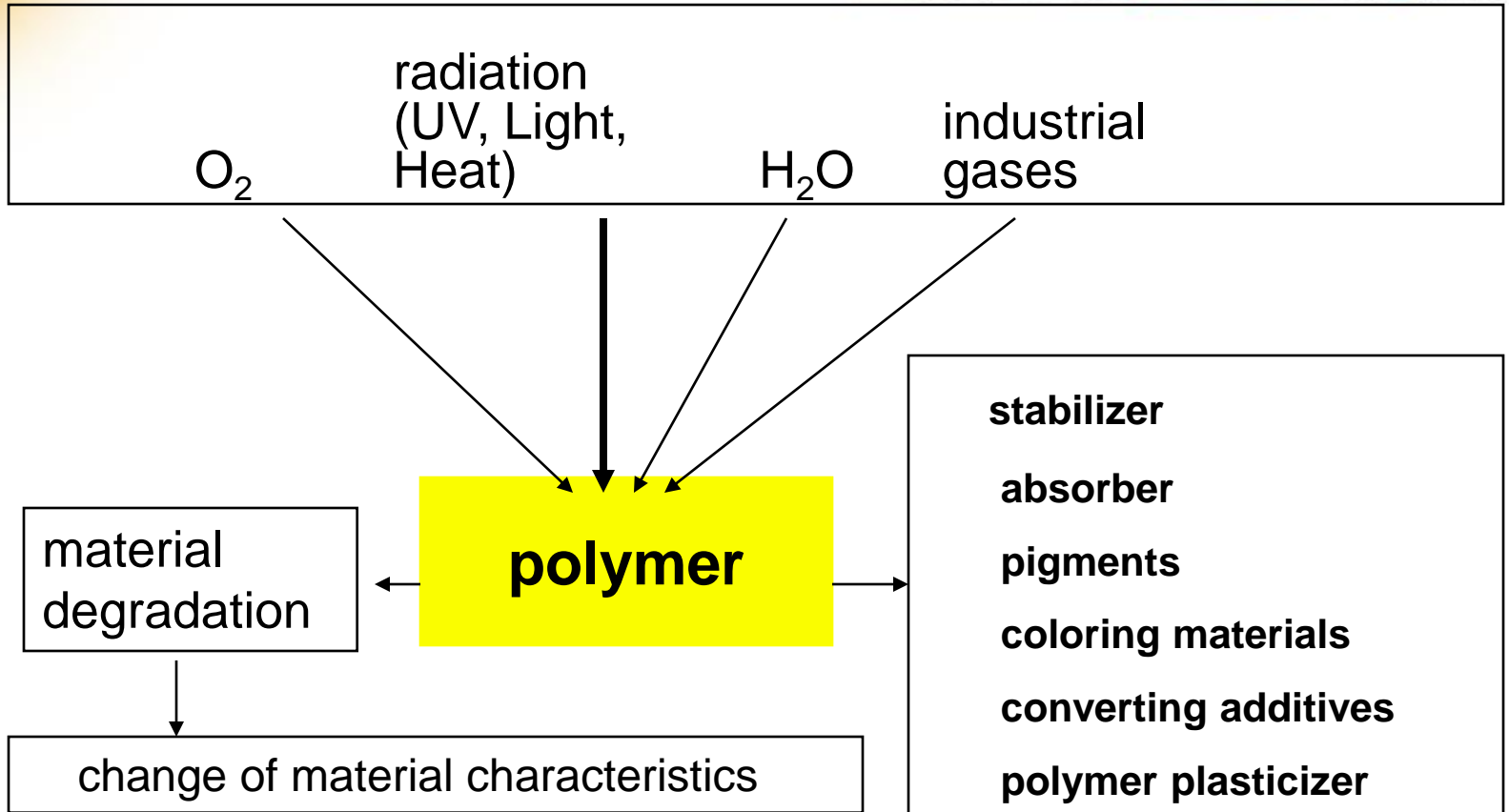



Introduction

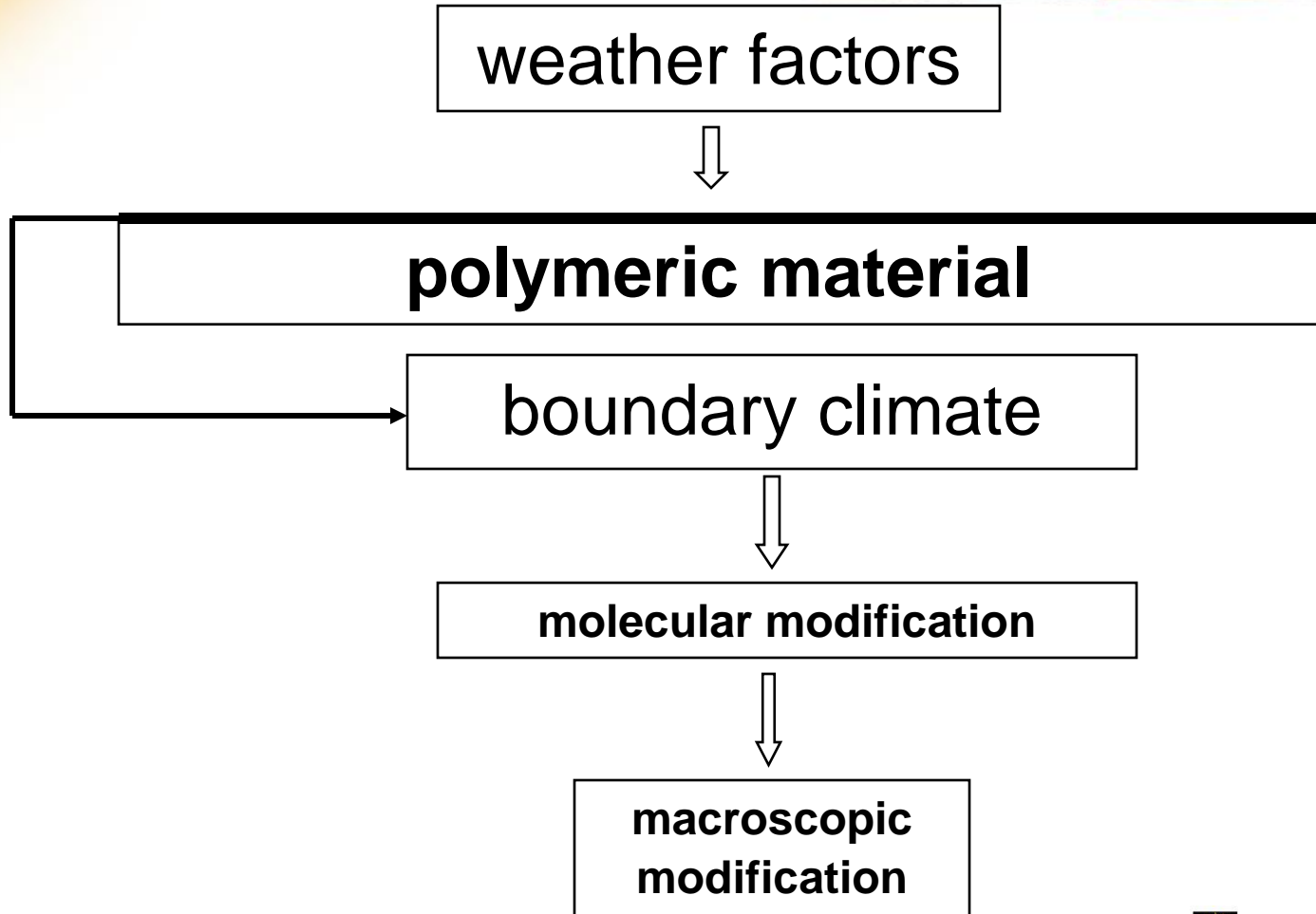



Introduction



natural weathering



artificial weathering (xenon)



solar simulation device





Introduction



- With regard to the appearance of signs of aging, it is generally exposure to radiation which is seen as the primary cause of aging
- In these cases, sunlight must be reproduced as realistically as possible by the equipment
- The spectral distribution as well as the irradiance of sunlight on the earth's surface are dependent on the location as well as on the time of day and the time of year
- The spectral distribution specified in CIE publication No. 85, Table 4, today serves as the reference spectrum for global radiation throughout the world



Spectral Energy Distribution



Spectral energy distribution of solar radiation in accordance with CIE, No. 85, Table 4 and filtered Xenon radiation

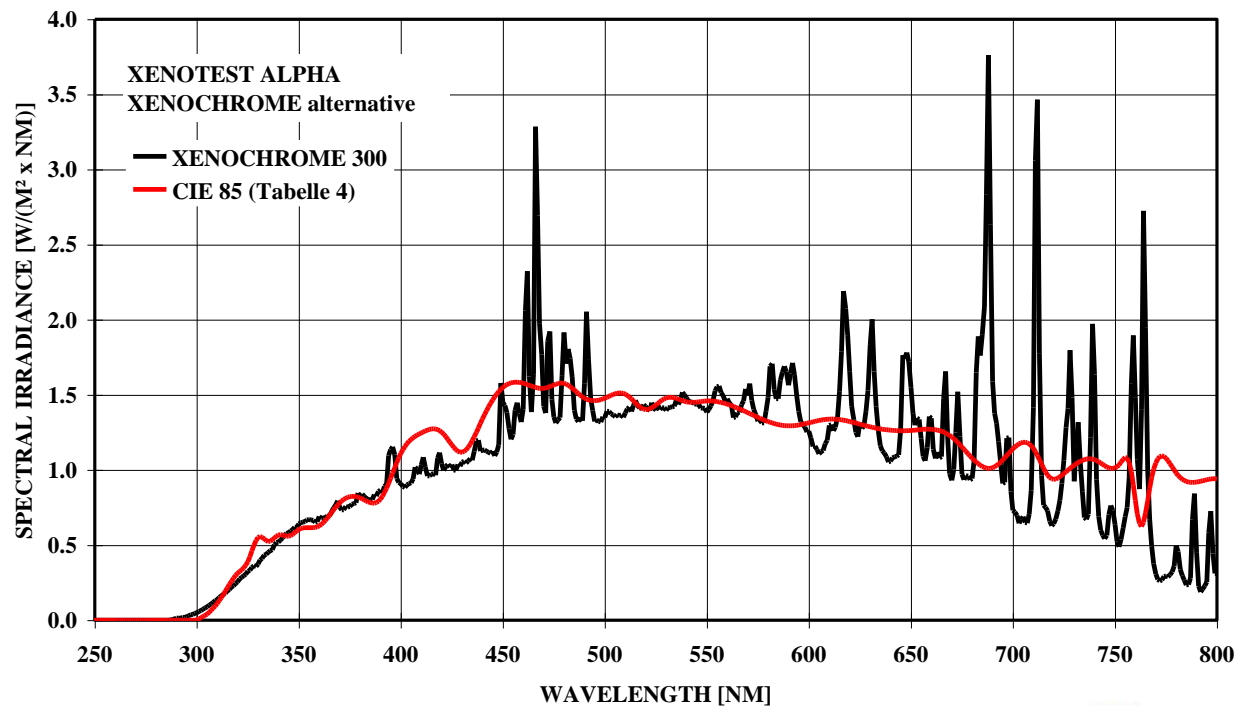



Selektive Filter Radiometers



- In order to meet the stringent requirements of current test standards (e.g., ISO 4892 or ISO 11341) for weathering tests, high-quality UV radiometers must be employed to measure and regulate the UV irradiance (ISO 9370)
- The most frequently employed, wavelength-sensitive radiometers offer broad band measurement in the 300nm to 400nm wavelength range, and narrow band measurement with maximum sensitivity at 340nm to simulate daylight and daylight behind window glass
- Radiometers whose narrow band measurements are spectrally most sensitive at midrange wavelengths around 420nm are employed exclusively for the simulation of daylight behind window glass



Selektive Filter Radiometer



Typical relative spectral sensitivities of selective filter radiometers

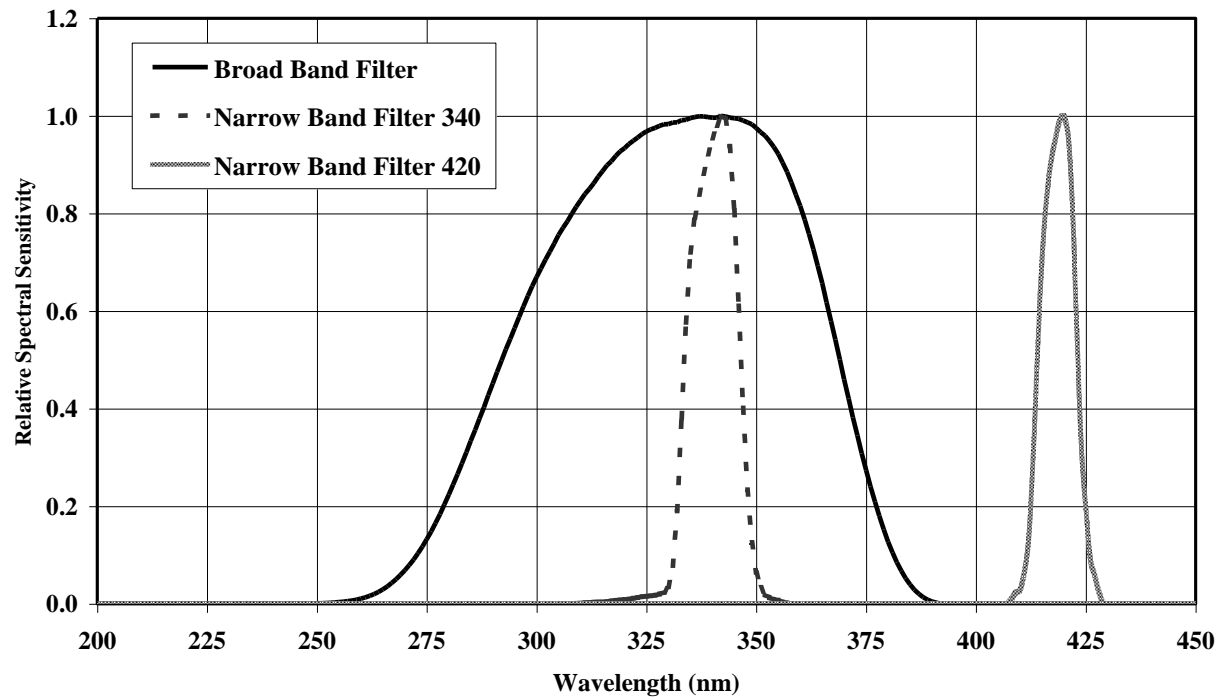



Design and Characteristics



Filter radiometer (XenoCal) with its optical components

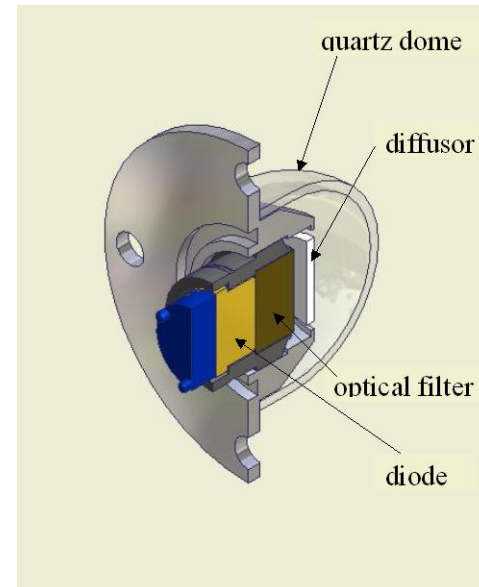
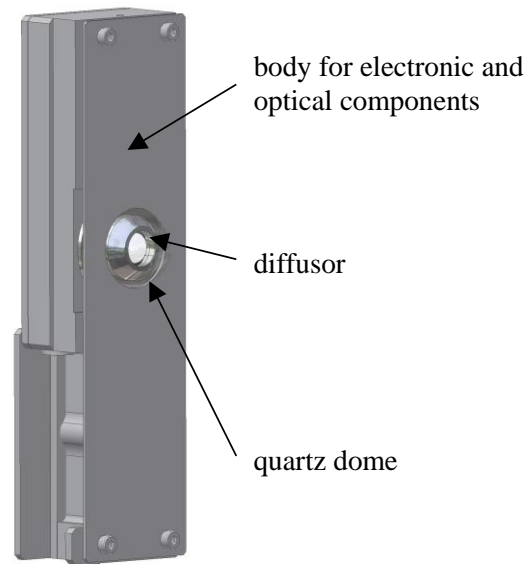



Design and Characteristics

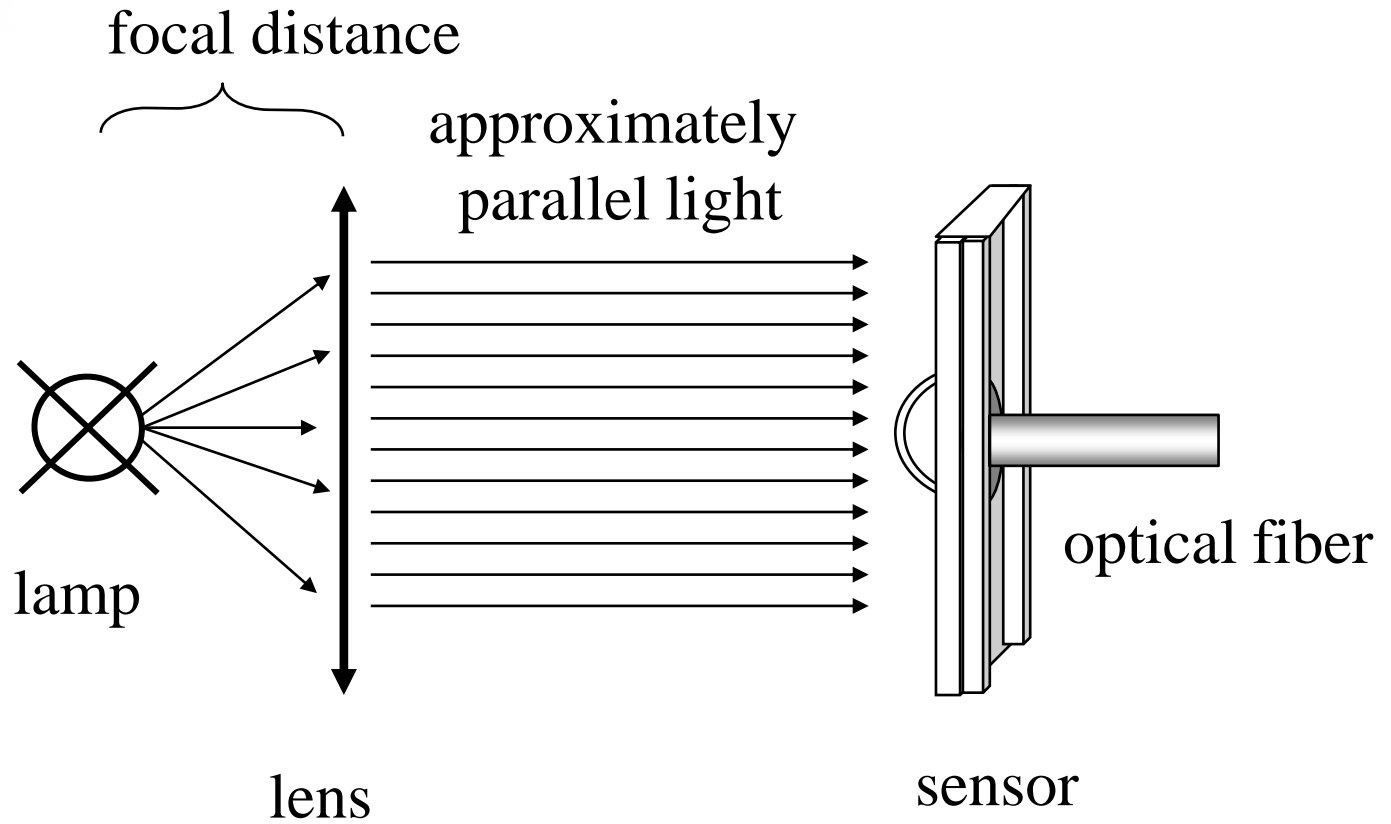

Fixture for measuring cosine response



Design and Characteristics



Illustration of the angle-dependent measurement signal of a XenoCal BB 300-400 sensor. A cosine-shaped decline of the measurement signal is considered to be ideal

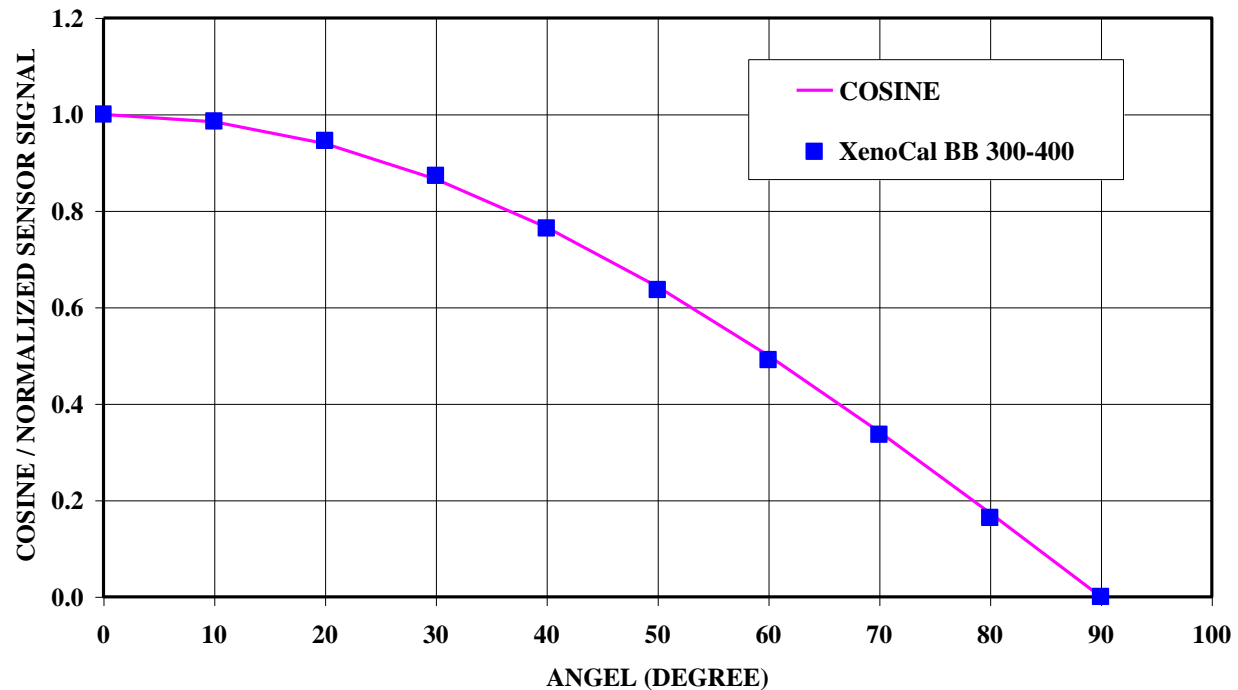



Design and Characteristics



Relative error in the cosine correction of the measurement from Figure before in accordance with DIN EN 13032-1

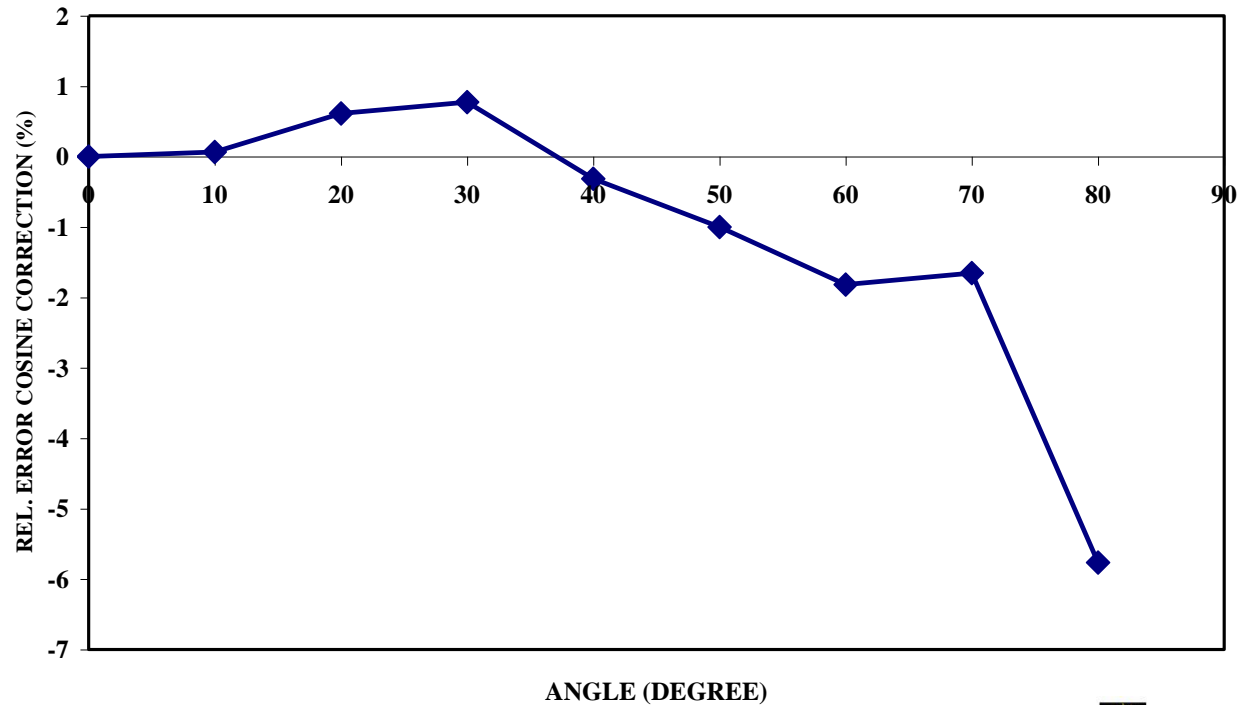



Design and Characteristics



Measurement signals from two temperature-compensated XenoCal sensors in a weathering device

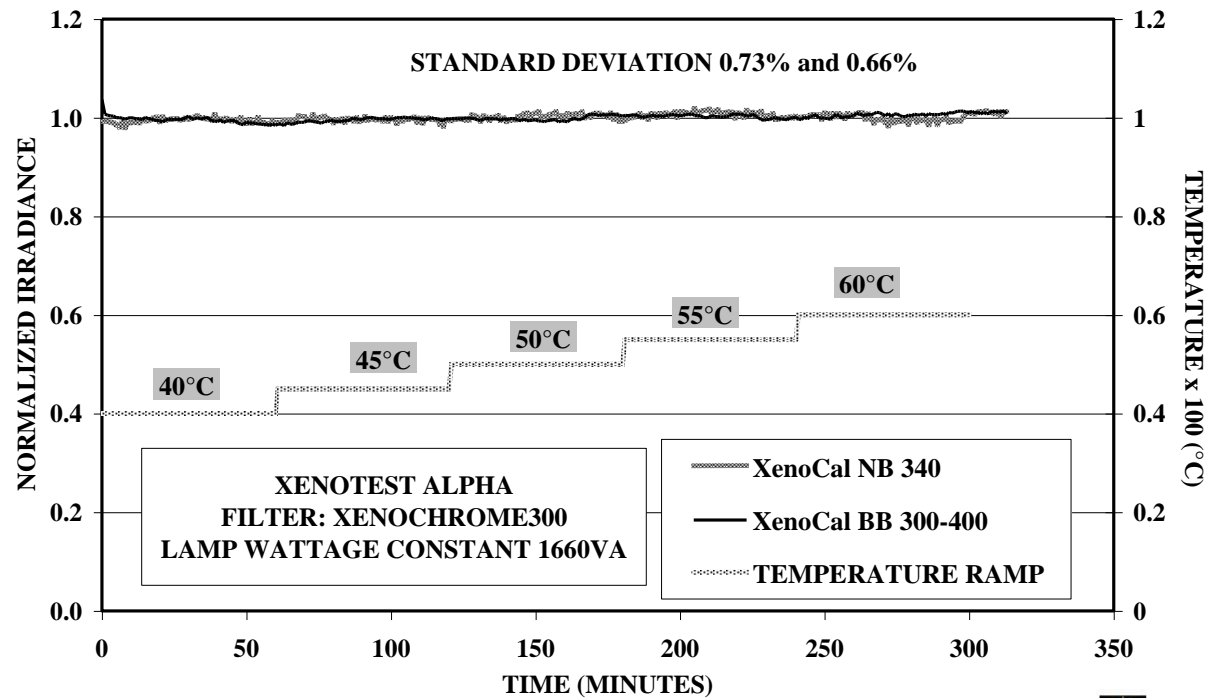



Calibration of Selective Filter Radiometers

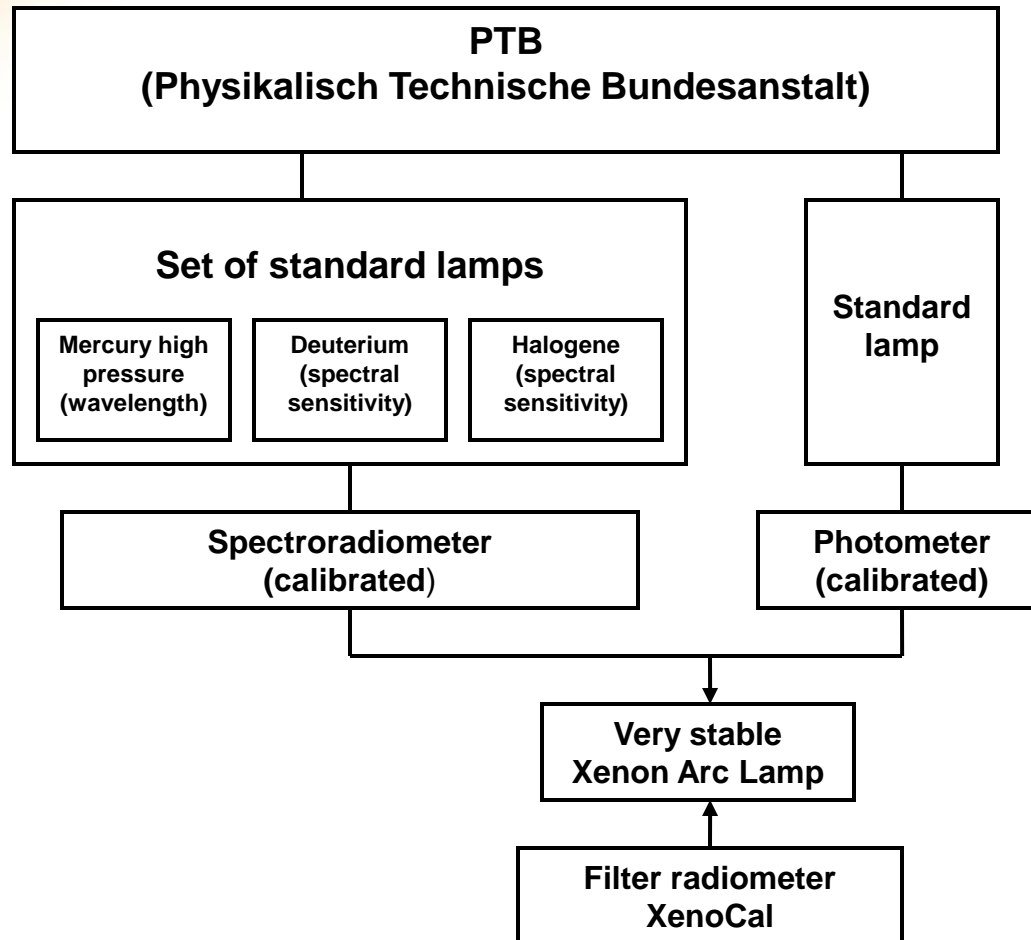

Calibration hierarchy for XenoCal filter radiometers



Xenon Lampe as a Reference Standard



Highly stable xenon lamp as an internal plant reference standard

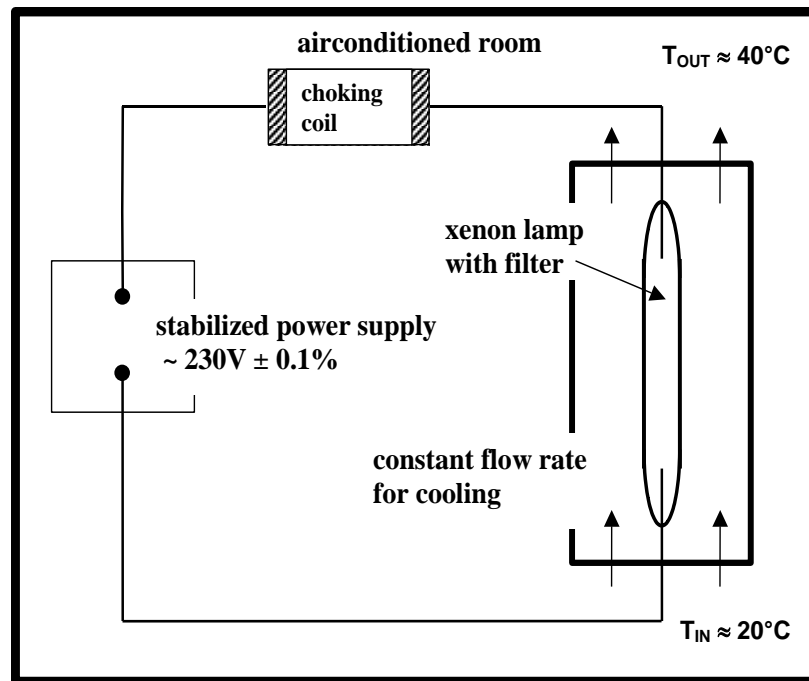



Xenon Lampe as a Reference Standard



Illustration of the xenon reference lamp over 4.5 hours, measured with a XenoCal UV sensor

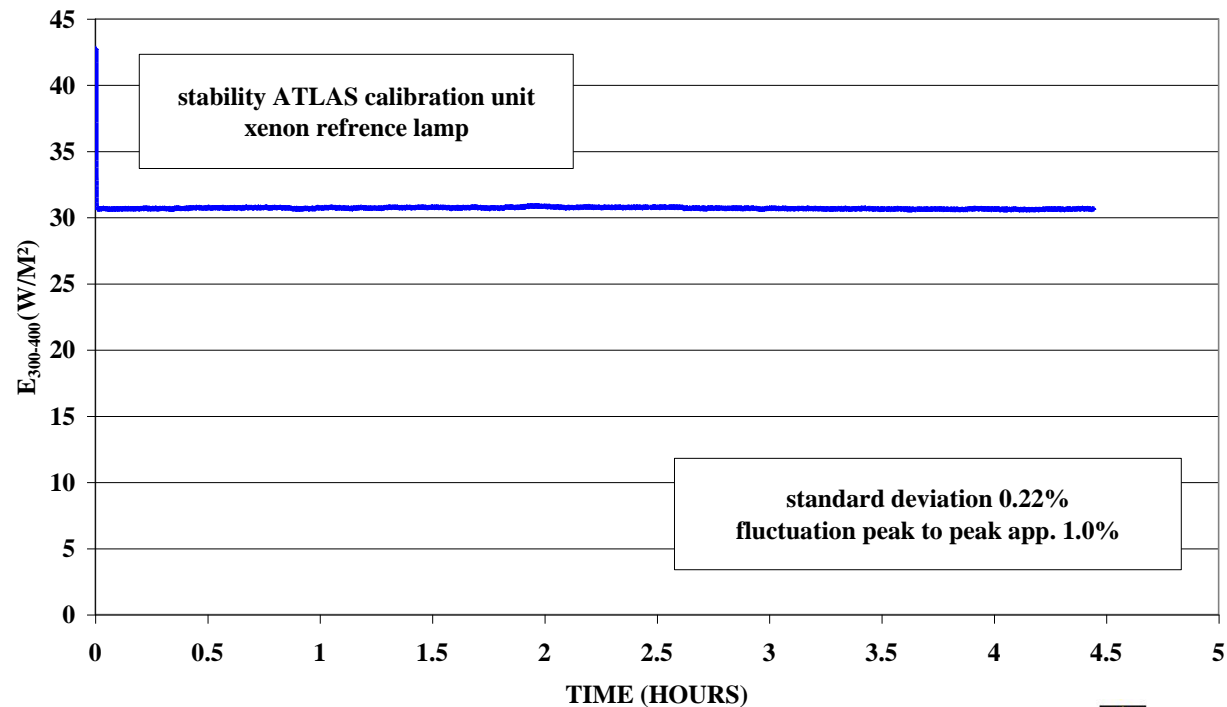



Xenon Lampe as a Reference Standard



Spectral energy distribution from 250nm to 400nm at the ATLAS calibration stand (xenon reference standard)

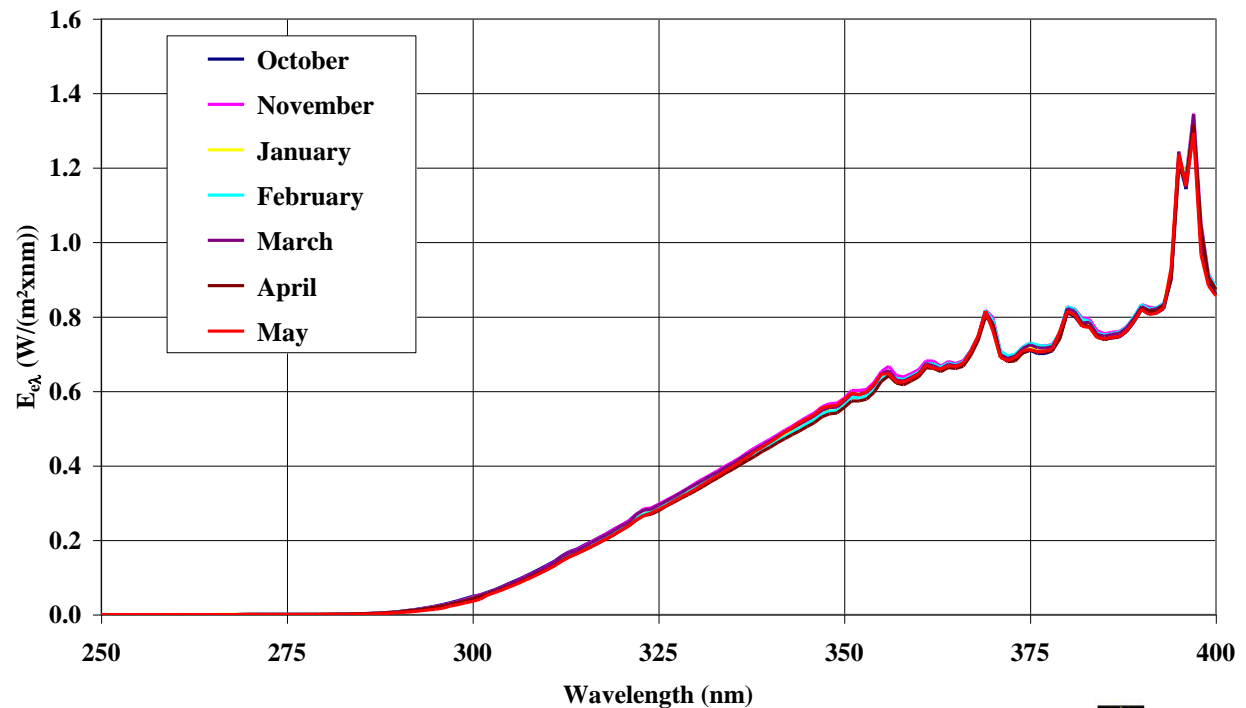



Xenon Lampe as a Reference Standard



Long-term stability of the xenon reference standard over a 300-hour period at various wavelength ranges, standardized to the irradiance at 0 hours

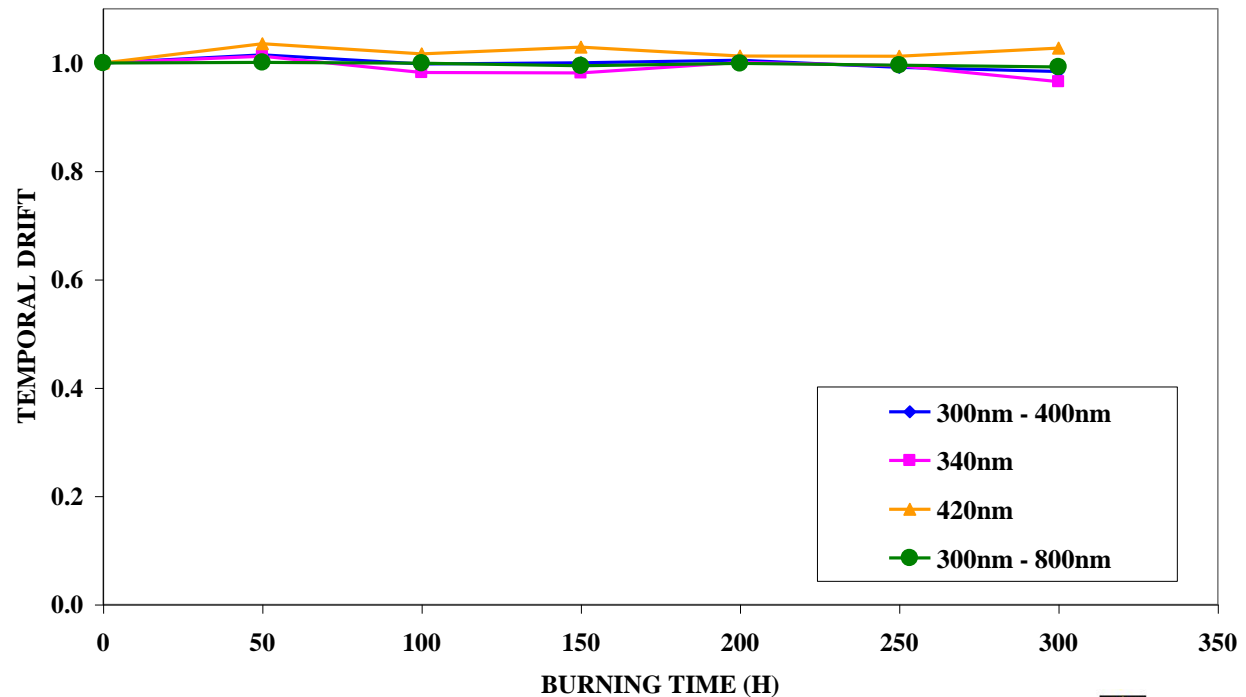



Xenon Lampe as a Reference Standard



Standard deviations from the mean for the spectra from the period from October, to May

Wavelength range	Standard deviation
nm	(%)
300 - 400	0.71
340	1.12
420	1.34
300 - 800	0.32



Spectral Correction Factor



Spectral energy distributions of filtered xenon radiation and window-glass filtration in comparison with the calibration source (Xenon reference standard). All spectra standardized to 50W/m². Standardized spectral sensitivity of a XenoCal BB 300-400 filter radiometer

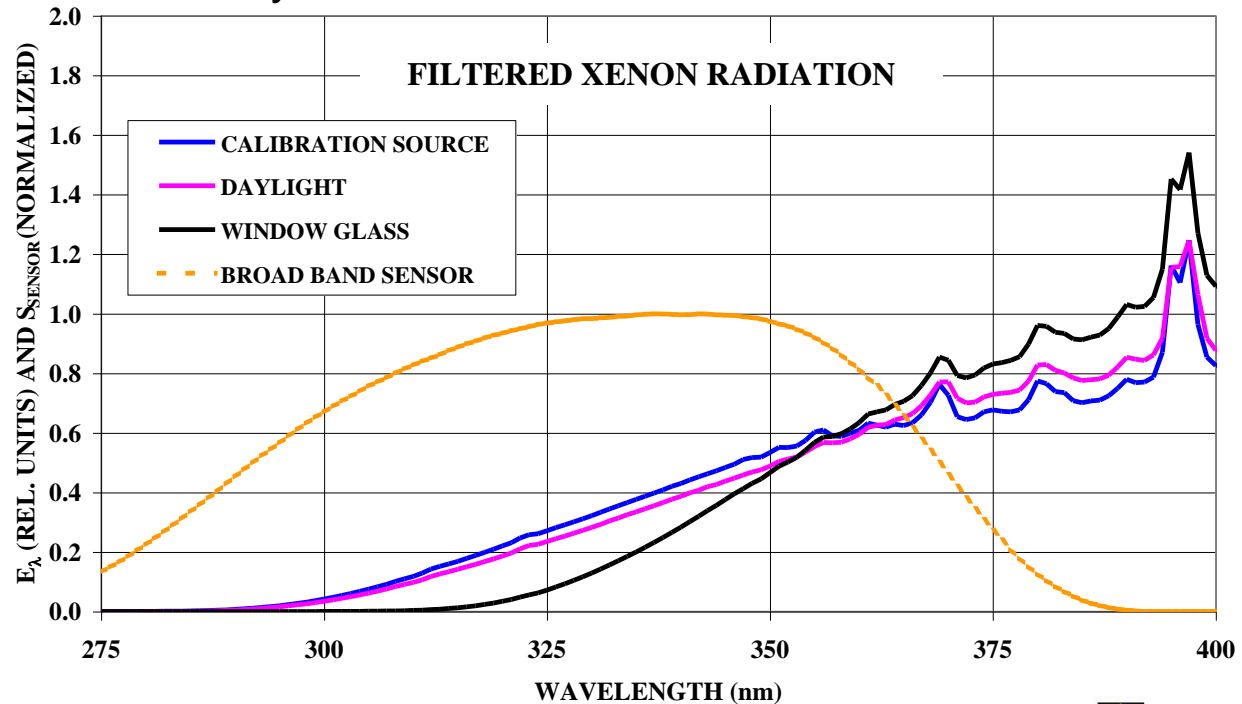



Spectral Correction Factor



$$a = \frac{\int_{\lambda_0}^{\lambda_1} s_{Sensor}(\lambda) \cdot E_{e\lambda,cq} \cdot d\lambda}{\int_{\lambda_0}^{\lambda_1} E_{e\lambda,cq}(\lambda) \cdot d\lambda} \cdot \frac{\int_{\lambda_0}^{\lambda_1} E_{e\lambda,mq}(\lambda) \cdot d\lambda}{\int_{\lambda_0}^{\lambda_1} s_{Sensor}(\lambda) E_{e\lambda,mq}(\lambda) \cdot d\lambda}$$

- a - spectral correction factor (spectral mismatch)
- $s_{Sensor}(\lambda)$ - spectral sensitivity of the sensor
- $E_{e\lambda,cq}(\lambda)$ - spectral irradiance of the calibration source
- $E_{e\lambda,mq}(\lambda)$ - spectral irradiance of the measurement source



Sources of Errors in UV Radiation Measurements



Measurement uncertainties in radiometry

No.	Measurement uncertainty
1.	Standard lamp
2.	Spectroradiometer
3.	Xenon reference standard



Sources of Errors in UV Radiation Measurements



Measurement uncertainties in radiometry

No.	Measurement uncertainty	Type of error
1.	Standard lamp	
1.1	Ambient conditions	Coincidental
1.2	Lamp current stability	Coincidental
1.3	Lamp current strength	Systemic/coincidental
1.4	Distance between the lamp and the spectral radiometer's input optics	Coincidental
2.	Spectroradiometer	
2.1	Ambient conditions	Coincidental
2.2	Input optics (cosine error)	Systemic
2.3	Stray and false radiation	Systemic
2.4	Measurement electronics	Systemic / coincidental



Sources of Errors in UV Radiation Measurements



Measurement uncertainties in radiometry

No.	Measurement uncertainty	Type of error
3.	Xenon reference standard	
3.1	Ambient conditions	Coincidental
3.2	Voltage fluctuations (lamp wattage)	Coincidental
3.3	Distance between the lamp and the UV radiometer's input optics	Coincidental



Filter Radiometers for Weathering and Photo Stability Tests



Thank you !!

copyright 1995 phile@oit.edu