

# A History of Solar and Ultraviolet Radiometer Calibration Standards



---

Gene Zerlaut and Warren Ketola  
**Franc Grum Memorial Lecture**  
CORM 2007



# Genesis of Radiometer Calibration Standards

---

## Applications

- U. S. Space Program (1960s – 1975)
- Solar Energy Utilization (1975 – 1986)
- Materials testing (outdoor exposure testing – more sophisticated indoor testing); ca 1992

## Instruments

- Absolute Cavities (JPL/Eppley)
- Precise solar measurements required for product certification
- Direct solar and solar ultraviolet irradiance, global hemispherical irradiance



# Definitions

---

- **Absolute Cavity Pyrheliometer:**
  - A self-calibrating, electrical-substitution, view-limited thermopile radiometer the aperture of which is maintained normal to the sun's beam radiation.
- **Pyrheliometer:**
  - Same as an absolute cavity except that it is not self-calibrating; i.e., a view-limited radiometer the aperture of which is maintained normal to the sun's beam component
- **Pyranometer:**
  - A radiometer used to measure all radiation incident on its flat receiver from a  $2\text{-}\pi$  steradians hemisphere

# U.S. Space Program: Impetus for absolute radiometry



- Spacecraft borne radiometers used to measure solar radiation from space
- One purpose was to more firmly establish the Solar Constant
- Absolute cavity pyrheliometers employed on board spacecraft

The white paint on the parasol used to fix tear in Skylab's skin was IITRI's S13G-LO ZnO-pigmented polydimethylsiloxane

# Absolute Cavity Radiometers: Pyrheliometers

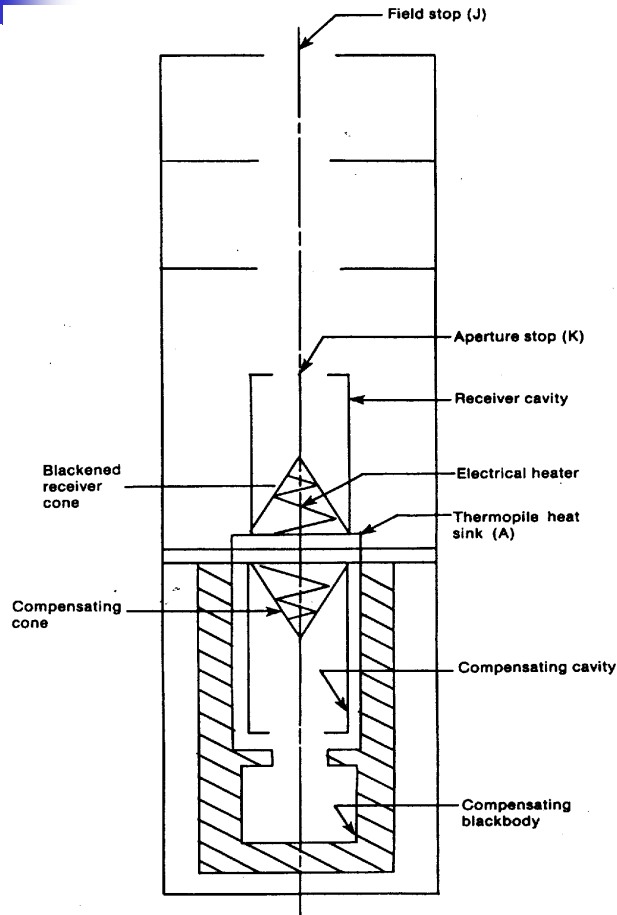

**Schematic of a Cavity Radiometer**

- On early satellites to measure the solar constant
- Used to calibrate pyranometers and field pyrhemometers for national solar programs (HW & PV)
- Used in sophisticated measurement stations for accurate solar irradiance measurements

# Attributes of an Absolute Cavity Radiometer

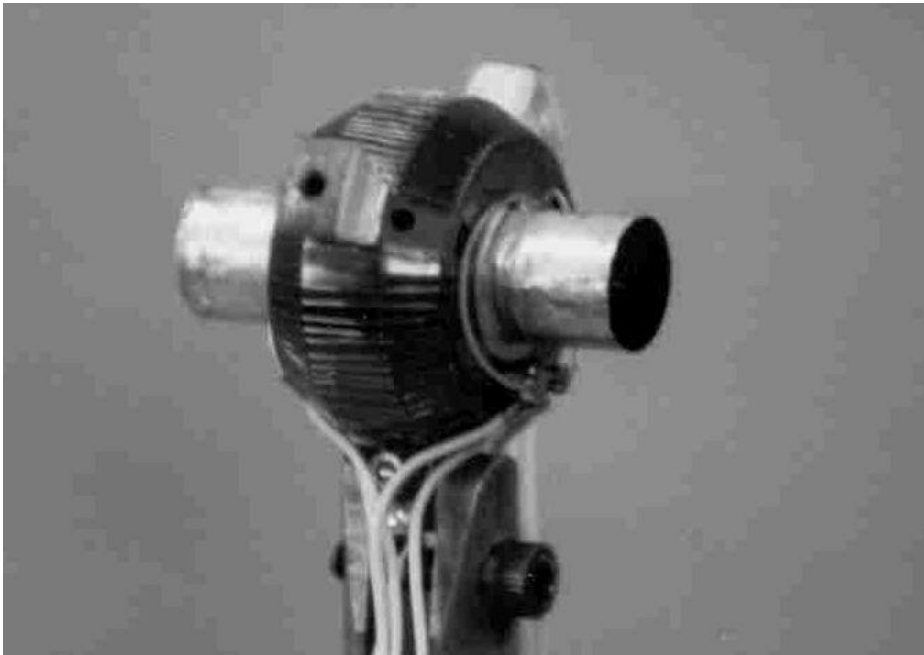

**Dual cavities and thermopile (center)  
of the Eppley HF Absolute Pyrheliometer**

- Characterized not calibrated
- Measurement realized from electrical substitution of emf generated by direct beam radiation
- Thermopile alternately receives "heat" from sun-heated cavity and electrical heater

# An IPC held at WMO's Solar Radiation Center - Davos



International Pyrheliometric Conference (IPC)

# Non-cavity pyrheliometers being compared at Davos



# Realization of the World Radiometric Reference (WRR)

## WRG

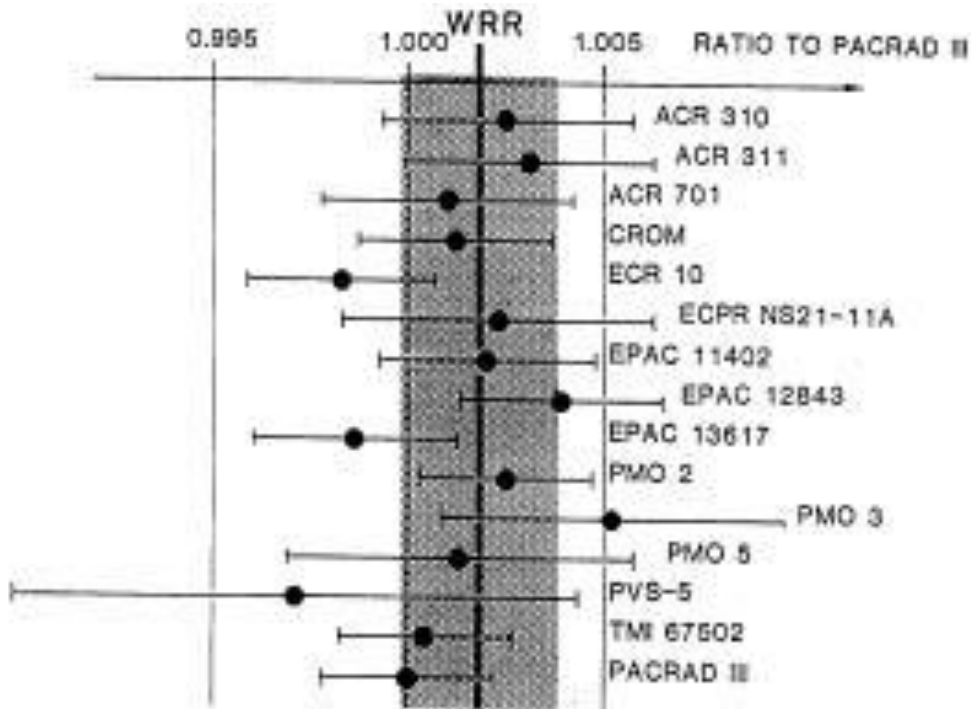

- WRR Scale maintained by World Standard Group (WSG)
  - WSG Consists of 7 donated Absolute Cavity Pyrheliometers
- International Pyrheliometric Conferences (IPCs) held every 5 years
  - Always held in Davos, Switzerland

**1979: WRR Established by 15 Cavities**

# New River Intercomparison of Absolute Cavity Pyrheliometers



Foreground: DSET's Eppley Model HF Absolute Cavity Pyrheliometer SN 17142

- NRIPs hosted by DSET Laboratories, New River, Arizona
- Funded alternately by SERI and NOAA
- Seven NRIPs held from November 1978 to November 1985
- 34 Instruments from 26 worldwide organizations participated

# Results of NRIP 7 (Nov. 1985)

NOAA Technical Memorandum ERL ARL-161



RESULTS OF THE NRIP 7 INTERCOMPARISON NOVEMBER 18-21, 1985

Donald Nelson  
Rudy Haas  
John DeLuisi  
Gene Zerlaut

Air Resources Laboratory  
Silver Spring, Maryland  
November 1987

noaa NATIONAL OCEANIC AND ATMOSPHERIC ADMINISTRATION / Environmental Research Laboratories

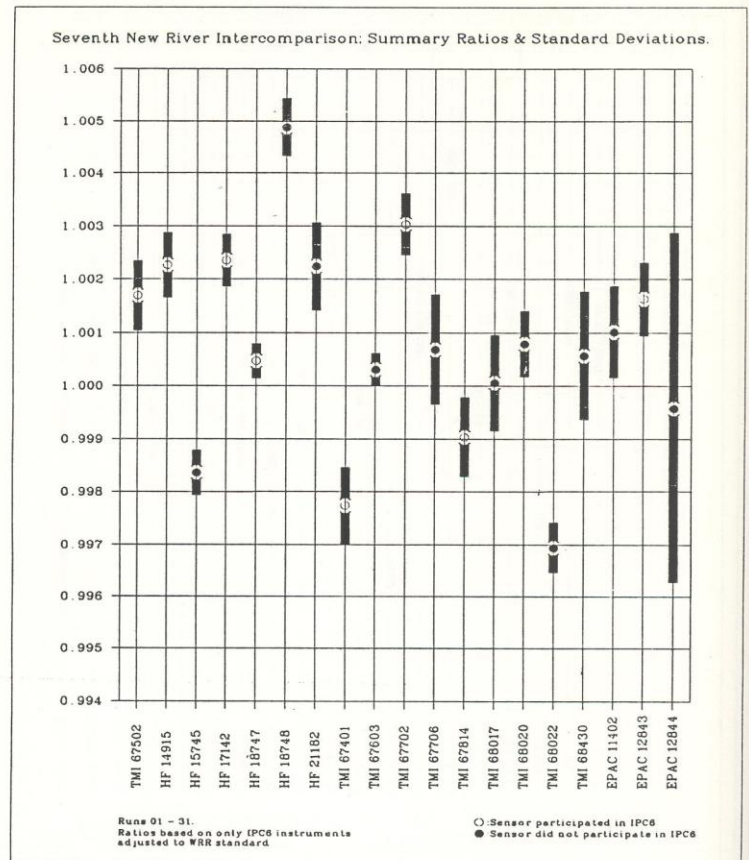
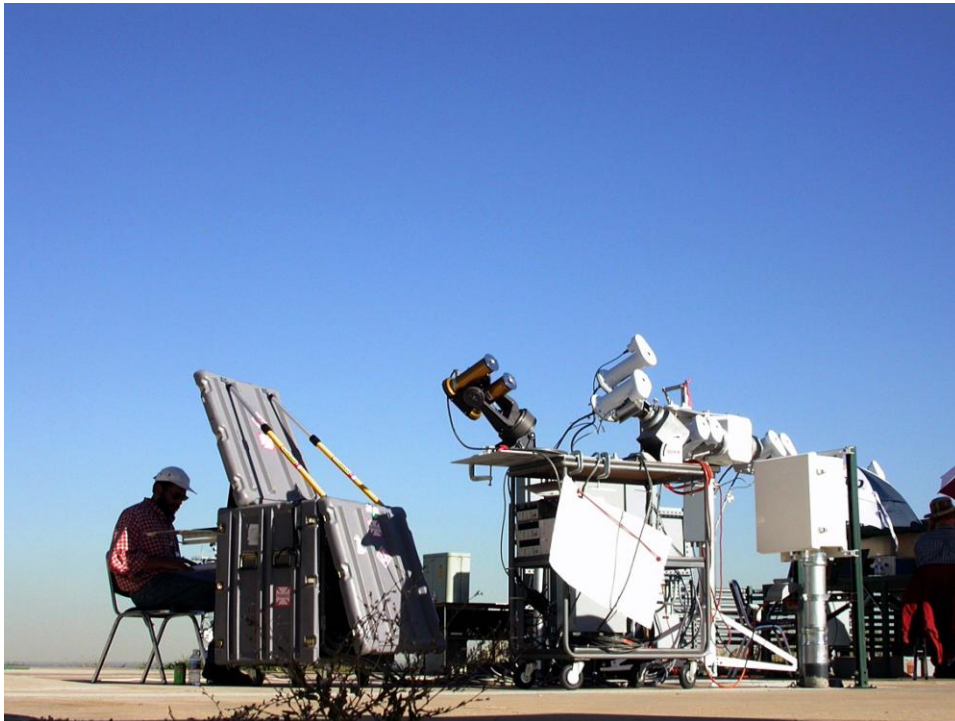

Figure 12. Both Days Summary Ratio and Corresponding Standard Deviation for Each Instrument Based upon the Adjusted Measurements of the IPC6 Instruments.

# Intercomparison of Cavities at NREL's SRRL



- The NREL Intercomparisons are held every 5 yr
- Purpose is to
  - “Bring” the WRR to U.S. after every IPC
  - Maintain the WRR in the United States between IPCs

# Intercomparison of Absolute Cavity Radiometers at NREL's SRRL





# Solar Collector Testing Drove Need for Standardization

---

- Pyranometers not calibrated periodically exhibited loss in sensitivity – resulting in low irradiance measurements and solar collector efficiency errors (high)
- In the early days, manufacturers sought testing laboratories whose efficiency plots were high
- NBS, DSET Laboratories Inc. and certain manufacturers led efforts to develop pyranometer calibration standards in ASTM (First in Committee E21 and then E44)

# Importance to Solar Hot Water Collector Testing

$$\eta = F_R \left[ K_{\tau\alpha} - U_L \left( \frac{t_f - t_a}{I_s} \right) \right]$$

**Hottel-Whillier Governing Equation of a solar HW collector**

$I_s$  = total solar irradiance

- Products sold on basis of efficiency
- Efficiency relates to percent of solar energy received that is converted to heat
- Efficiency values became very competitive in product certification programs



# DSET's Role in Initiation of Standardization

---

- By 1978, DSET Laboratories had become a major solar thermal collector test laboratory and purchased our first of two Eppley HF Cavity Pyrheliometers.
- With support from John Hickey of The Eppley Laboratories, DSET was selected to host the previously mentioned New River Intercomparisons.
- Simultaneously, DSET began the commercial calibration of pyranometers and pyrheliometers with the HF Cavity Radiometer as the primary reference
  - DSET was then and is still the only independent, commercial calibration laboratory recognized as qualified to perform these calibrations.

# Calibration of a Pyranometer Using a Pyrheliometer - II

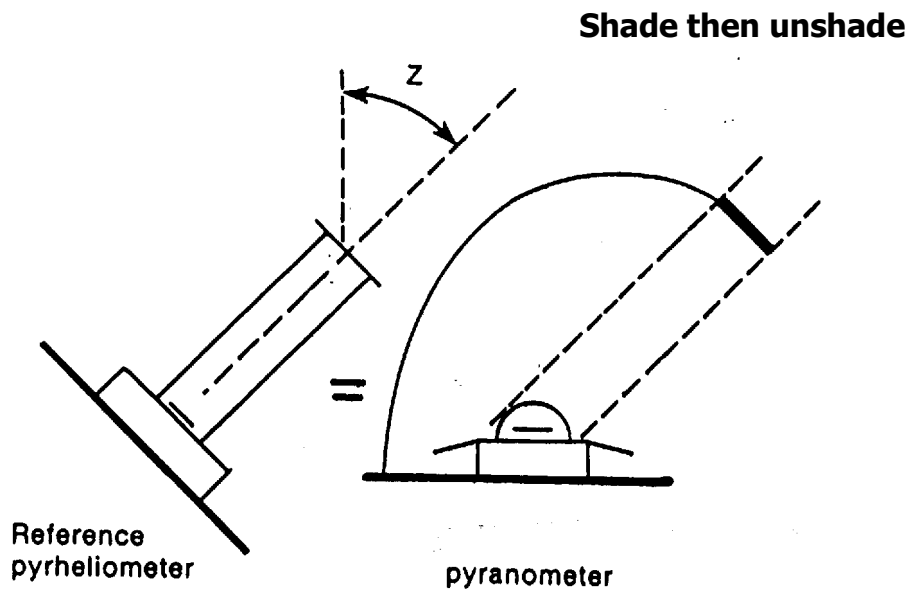

$$I_d \cos Z = (V_U - V_{Sh}) K^{-1}$$

- Shade-Unshade Method
  - Reference pyranometer is alternately shaded and unshaded
  - Difference is the direct irradiance
- Arguably is more precise than the component summation method

# Calibration of a Pyranometer Using a Pyrheliometer - I

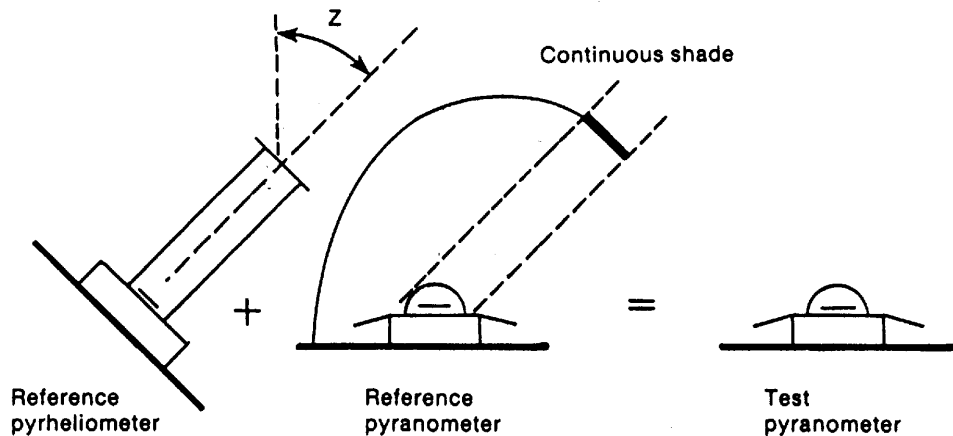

$$I_d \cos z + I_{sd} = V_t k^1$$

Also known as the continuous shade method

- Component summation method
  - Direct plus diffuse equals total
- Advantage of this method is ability to calibrate a large number of pyranometers simultaneously



# Solar-Initiated Standards Activities (Standard Test Methods)

---

- ASTM Committee E44 on Solar Energy. Formed 1978 (200 members, 10 subcommittees)
  - E 913-82 Calibration of Reference Pyranometers with Axis Vertical by the Shading Method (**Replaced and Withdrawn**)
  - E 941-82 Calibration of Reference Pyranometers with Axis Tilted by the Shading Method (**Replaced and Withdrawn**)
  - E 816 (ca 1985) Calibration of Pyrhemimeters by Comparison to Reference Pyrhemimeters (**Expanded 1990s**)
  - E 824 (ca 1985) Transfer of Calibration from Reference to Field Pyranometers (**Expanded and title change 1990s**)



# ASTM E44: Standard reference solar spectral energy distributions

---

- ASTM E 891-87 Tables for Terrestrial Direct Normal Solar Spectral Irradiance for Air Mass 1.5 (**Replaced and Withdrawn**)
- ASTM E 892-87 Tables for Terrestrial Solar Spectral Irradiance at Air Mass 1.5 for a 37-Deg Tilted Surface (**Replaced and Withdrawn**)
  - It should be noted that these standard reference spectra were developed by SERI using the “Bright” radiation code

# International Standardization: ISO TC 180, SC2 on Climate

- TC180 was organized in May 1981 with Australia taking the Secretariat
- Germany became the Secretariat of SC2 on Climate (DIN)
- ASTM E44 calibration standards were a major resource for TC180/SC2
- The U.S. was an active participant from start

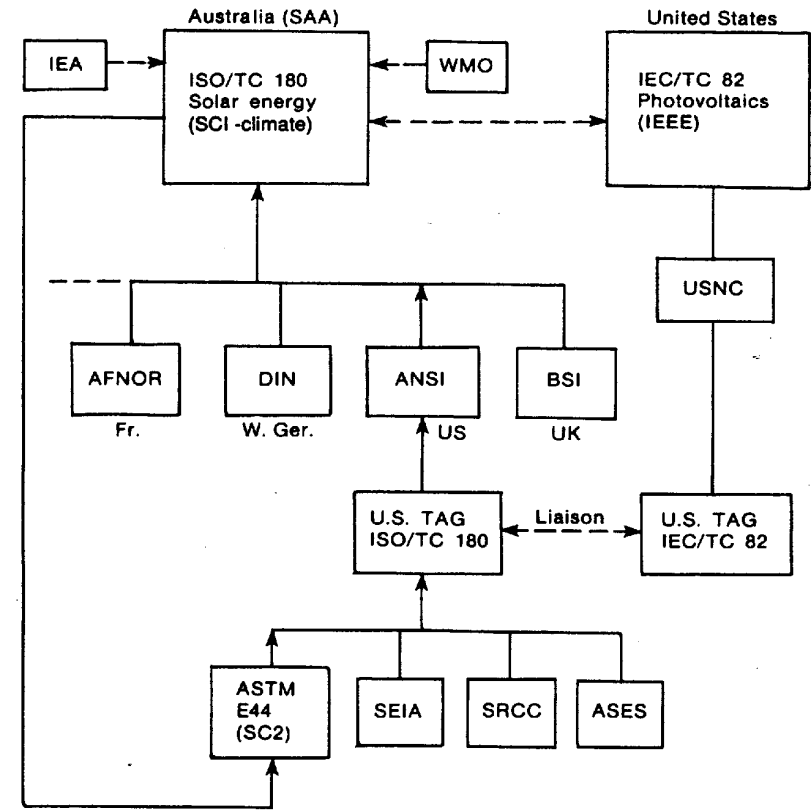



# Correspondence Between E44 and ISO/TC180 SC2

---

## Calibration Standards

- ASTM E 816
- ASTM E 824
- ASTM E 913
- ASTM E 941
- ISO 9059
- ISO 9847
- ISO 9846
  - Covers E 913 & E 941

---

## Standard Solar Reference Spectra

- ASTM E 891
- ASTM E 892
- ISO 9845-1
  - Covers E891 & E 892

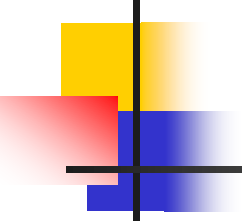

---

**On January 31, 1986, Congress failed to renew the solar tax credits. As a result the domestic solar hot water industry died in a matter of several days. E44 lingered for a time and then, except for Photovoltaics, Geothermal, and Wind Subcommittees, it became largely inactive.**

# “Weathering” of Materials became an impetus for renewed interest in calibration – under aegis of ASTM G03

- In early 1970's, DSET Laboratories became the first outdoor test lab to monitor weathering effects as a function of accumulated solar and solar ultraviolet radiation
- Other testing labs were slow to follow
- By late 1980s and early 1990s, other labs and manufacturers of accelerated weathering chambers began measurement programs

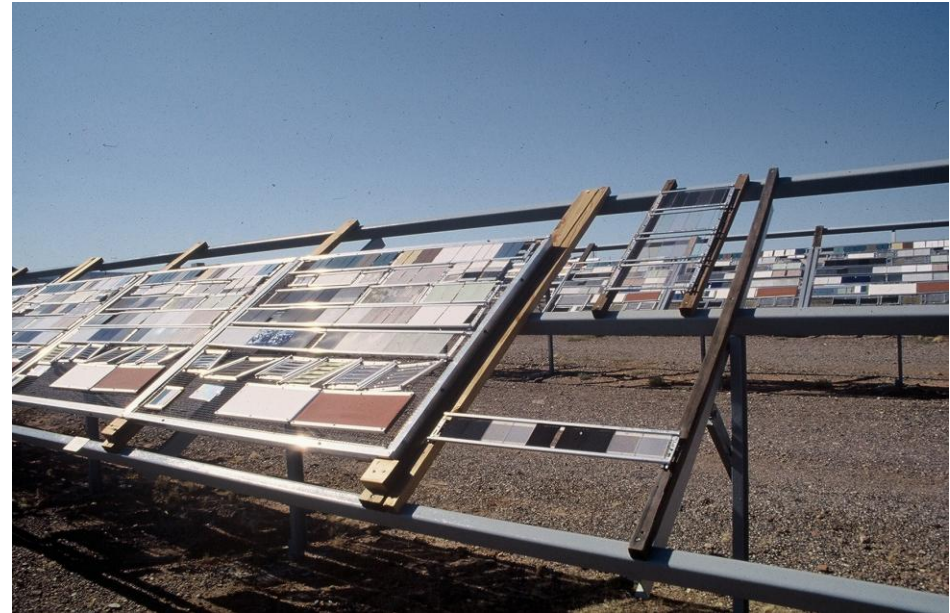

Exposure test field at DSET north of Phoenix

# ASTM G03 on Weathering and Durability – SC09 on Radiometry-



Atlas's Everglades Test Laboratory in  
South Miami, Florida

- In early 1990s, all ASTM E44 calibration and spectral standards were transferred to ASTM G03.09
- The G03 standards development program has resulted in several revised and/or new calibration standards
- Also, ASTM E 891 and E 892 were withdrawn and replaced.

# Calibration Standards

## Promulgated by ASTM G03

---

- ASTM E 824-05 Transfer of Calibration from Reference to Field Radiometers
  - Revised to include both pyranometers and UV radiometers (Total UV, UV-A and UV-B)
- ASTM G 167-00 Calibration of a Pyranometer Using a Pyrhelimeter
  - Includes horizontal (axis vertical) and any tilt from the horizontal
- ASTM G 130-06 Calibration of Narrow- and Broad-Band Radiometers Using a Spectroradiometer
- ASTM G 138-96 Calibration of a Spectroradiometer Using a Standard Source of Irradiance
  - With respect to ISO/IEC 17025, there are no sources of accredited calibrations of "Standard Sources of Spectral Irradiance," i.e., of standard lamps – independent of NIST, NPL, PTB, etc.

# Atlas DSET Laboratories

- Depicted are:
  - Calibration of pyranometers to E 824 (foreground)
  - Direct spectral measurements – became G 130 (background)
  - Absolute direct measurements with Eppley HF Cavity – E 841 (became G 167)

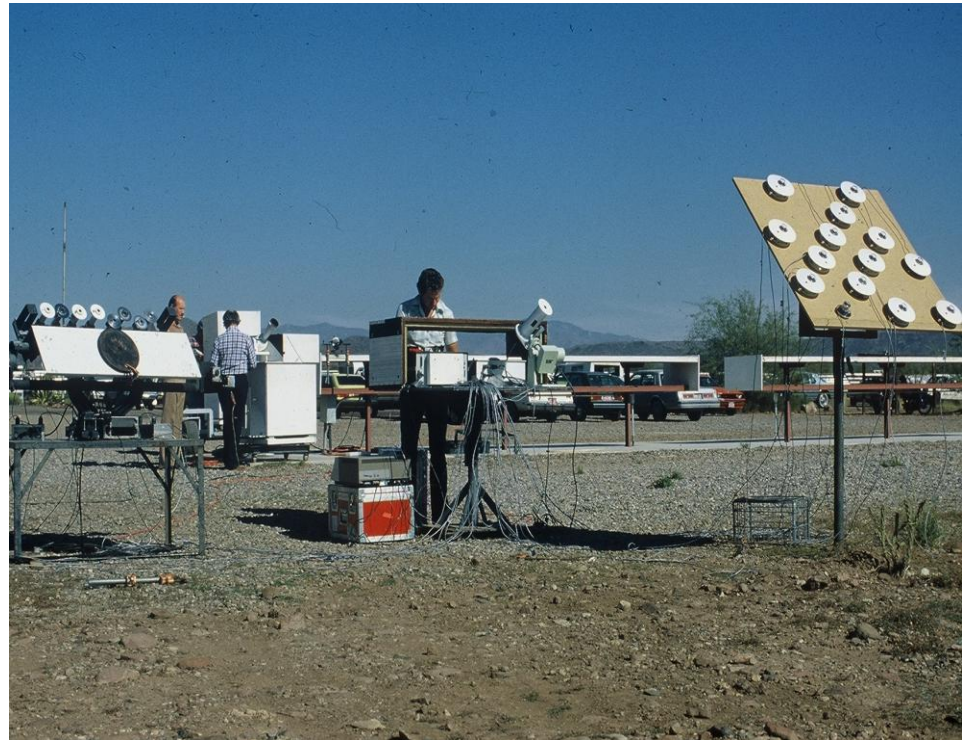

Atlas DSET is the only solar radiometer calibration laboratory accredited to ISO/IEC 17025

# Standards and WRR Traceability: Pyranometers/Pyrheliometers-

IPC = Internat. Pyrheliometric Conference  
WRR = World Radiometric Reference  
ACR = Absolute Cavity Radiometer  
CSM = Component Summation Method

 a field radiometer

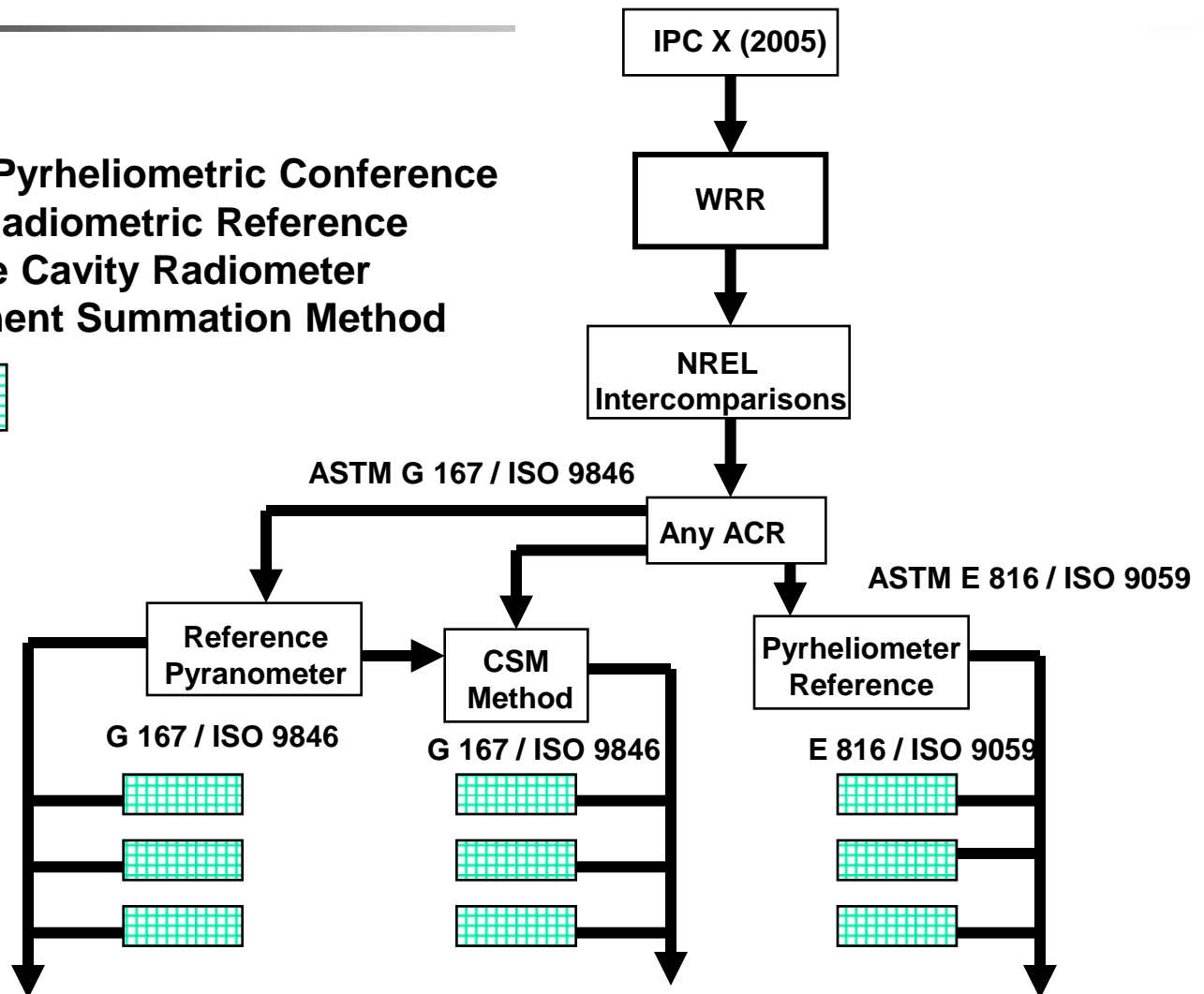

# Standards and NIST Traceability: UV Radiometers

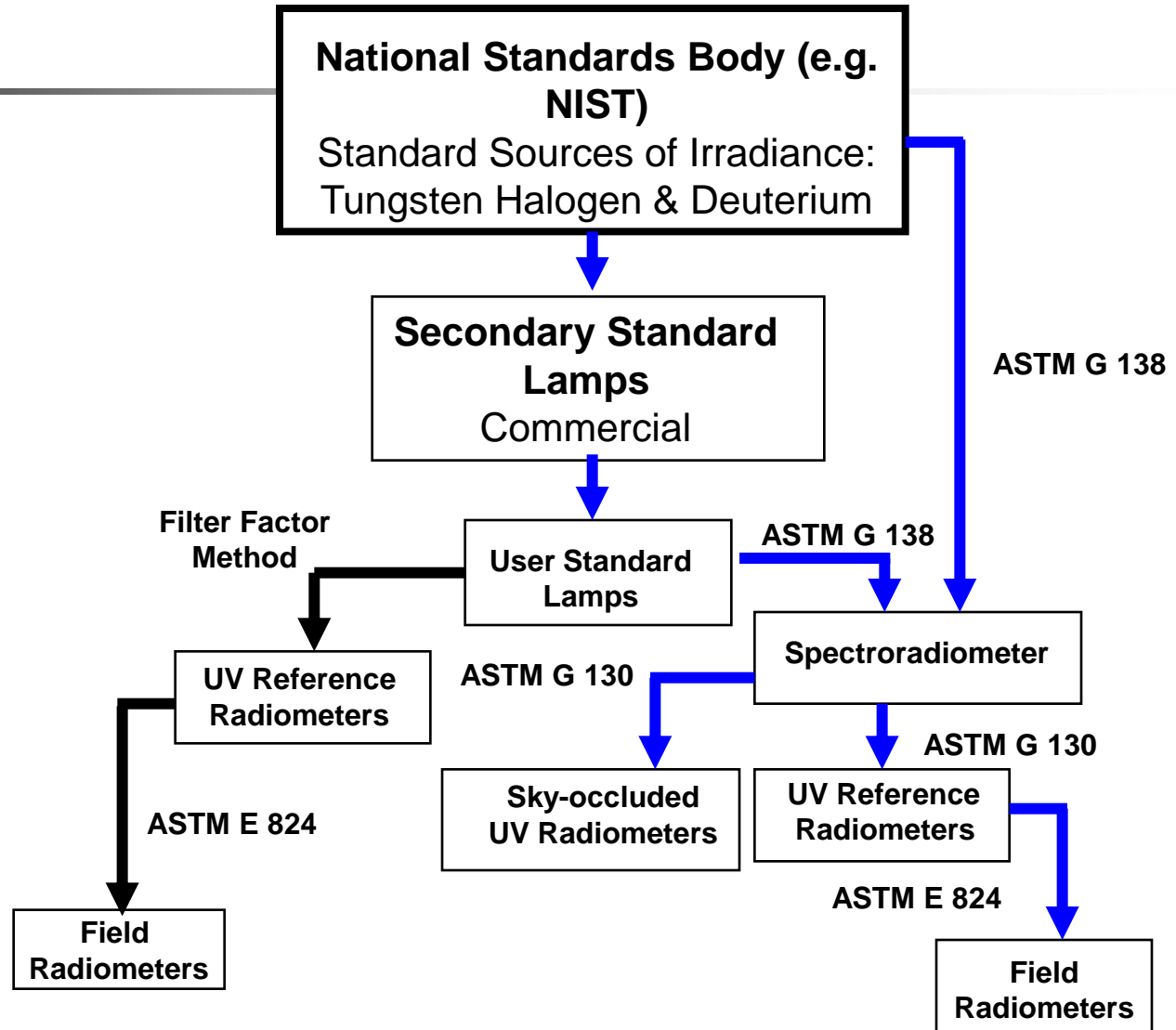

# ASTM G03.09: Transition from E 891/E 892 to G 173/G 177

- Since E 891 & E 892 could not be validated, same input parameters were input into SMARTS2 radiation codes (Christian Gueymard)
- G 173 Reference Solar Spectral Irradiances: Direct Normal and Hemispherical on 37° Tilted Surface
- G 177 Reference Solar Ultra-violet Spectral Distributions: Hemispherical on 37° Tilted Surface

SMARTS version 2.9.2 Computations for CIE 85 Tab #7

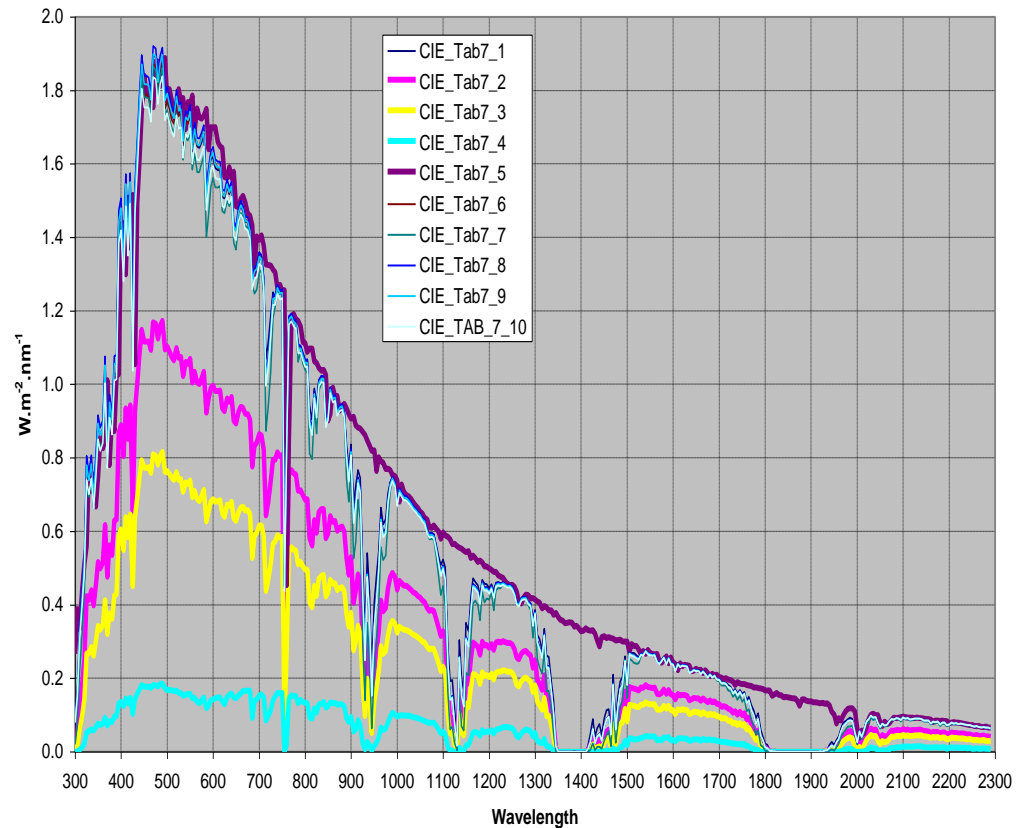



# Light Measurement in Weathering Tests

---

- Outdoor exposure tests
- Solar concentrating exposures
  - How consensus standards were used to resolve major differences in reported UV radiant exposure
- Artificial accelerated tests
  - Specifying spectral irradiance
  - Benchmarking against solar UV
  - Resolving an issue with measurement of UVB irradiance
- Problems still to be resolved using consensus standards



# Solar radiation measurements for outdoor weathering tests

---

- Bandpass
  - Total solar radiation
  - Solar UV radiation
  - Narrow band UV radiation
- Applicable standards
  - For total solar
    - Calibration: ASTM E824 or E941
    - Use: ASTM G 183
  - For solar UV
    - Calibration: ASTM G 130
    - Use: ASTM G 183
  - For narrow band UV
    - Calibration: ASTM G 130
    - Use ASTM G 183

ASTM G 130, G 138, and G 183 have been proposed as normative references in ISO DIS 9370

# The value of solar radiation measurements for outdoor exposures

Chain scission in a degradable polyolefin exposed at different times

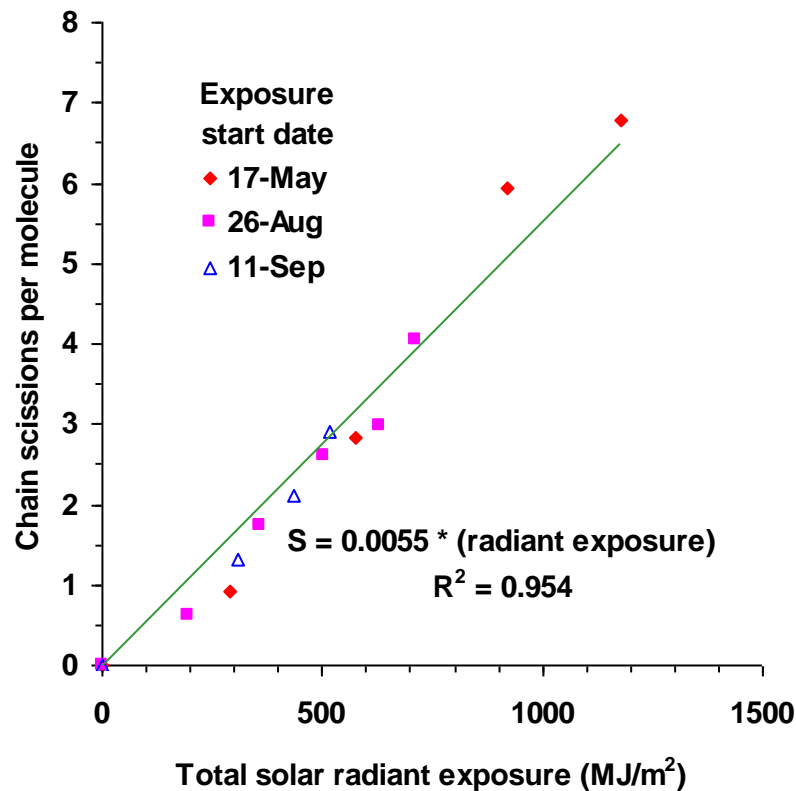
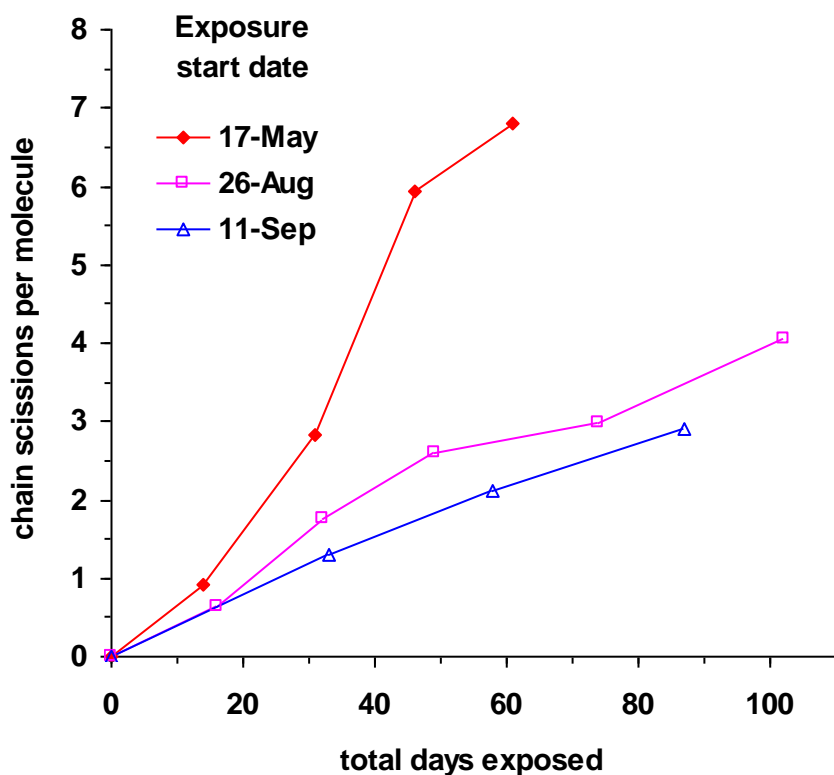

# Solar Concentrating Exposures



- Device description, operation, and use is described in ASTM G 90
- **MUST** measure direct total solar and solar UV

# Measurement of solar UV on solar concentrating exposures

- Must determine direct solar UV
- In early 1990's large differences in solar UV reported by two suppliers

year	supplier A	supplier A	supplier B	supplier B	Supplier A	Supplier B
	total solar	solar UV	total solar	solar UV	UV percent	UV percent
1989	61,692	2514	65,400	1833	4.1%	2.8%
1990	59,150	2351	61,637	1743	4.0%	2.8%
1991	56,485	2391	55,904	1564	4.2%	2.8%
1992	51,588	2113	46,250	1233	4.1%	2.7%
1993	59,083	2342	50,688	1357	4.0%	2.7%

- Supplier A used calculation based on direct / global ratio for total solar

# Measurement of solar UV on solar concentrating exposures

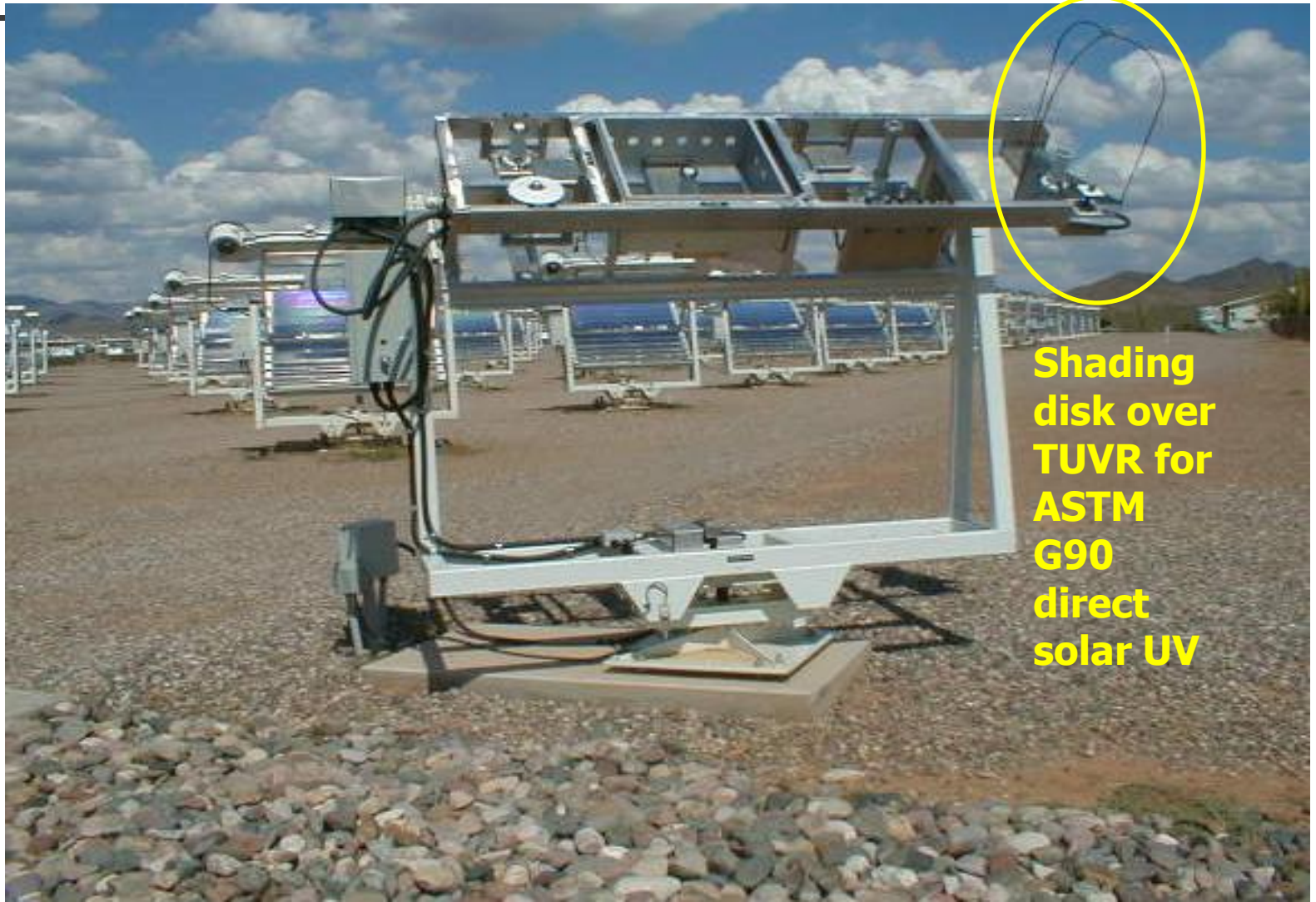

**Shading  
disk over  
TUVR for  
ASTM  
G90  
direct  
solar UV**

# Measurement of solar UV on solar concentrating exposures

- Revised ASTM G 90 to specify measurement procedure for direct solar UV
  - Collimating tube for TUVR radiometer
    - Better but small design or fabrication differences caused unacceptable variability
  - Shading disk over TUVR on solar tracker

year	supplier A		supplier B		Supplier A	Supplier B
	total solar	solar UV	total solar	solar UV	UV percent	UV percent
1989	61,692	2514	65,400	1833	4.1%	2.8%
1990	59,150	2351	61,637	1743	4.0%	2.8%
1991	56,485	2391	55,904	1564	4.2%	2.8%
1992	51,588	2113	46,250	1233	4.1%	2.7%
1993	59,083	2342	50,688	1357	4.0%	2.7%
<b>1994</b>	<b>55,661</b>	<b>1405</b>	<b>51,085</b>	<b>1294</b>	<b>2.5%</b>	<b>2.5%</b>



# Light measurement in artificial accelerated weathering tests

---

- Light sources
  - Carbon-arc, Fluorescent UV, Xenon-arc
- Spectral irradiance was only vaguely described
  - From ASTM G26-92
    - “borosilicate glass inner and outer filter to simulate the spectral power distribution of natural daylight throughout the actinic region”
    - “suggested minimum spectral irradiance levels are....0.35 W/m<sup>2</sup> at 340 nm”



# Light measurement in artificial accelerated weathering tests

---

- Performance-based standards for artificial accelerated weathering devices
- How to specify the spectral irradiance?
  - Absolute specification too restrictive
    - Too difficult to define / specify measurement conditions
  - Relative spectral irradiance distribution
    - Collect spectra and express irradiance in narrow bandpasses as a fraction of broader bandpass
    - Focus on UV region



# Specifying spectral irradiance

- ASTM G 155 or ISO 4892-2 daylight filters

**Table 1— Relative Ultraviolet Spectral Power Distribution Specification for Xenon Arc with Daylight Filters <sup>A,B</sup>**

Spectral Bandpass Wavelength $\lambda$ in nm	Minimum percent <sup>C</sup>	Benchmark Solar Radiation percent <sup>D,E,E</sup>	Maximum percent <sup>C</sup>
$\lambda < 290$			0.15
$290 \leq \lambda \leq 320$	2.6	5.8	7.9
$320 < \lambda \leq 360$	28.3	40.0	40.0
$360 < \lambda \leq 400$	54.2	54.2	67.5

# Xenon-arc with daylight filters compared to benchmark solar UV

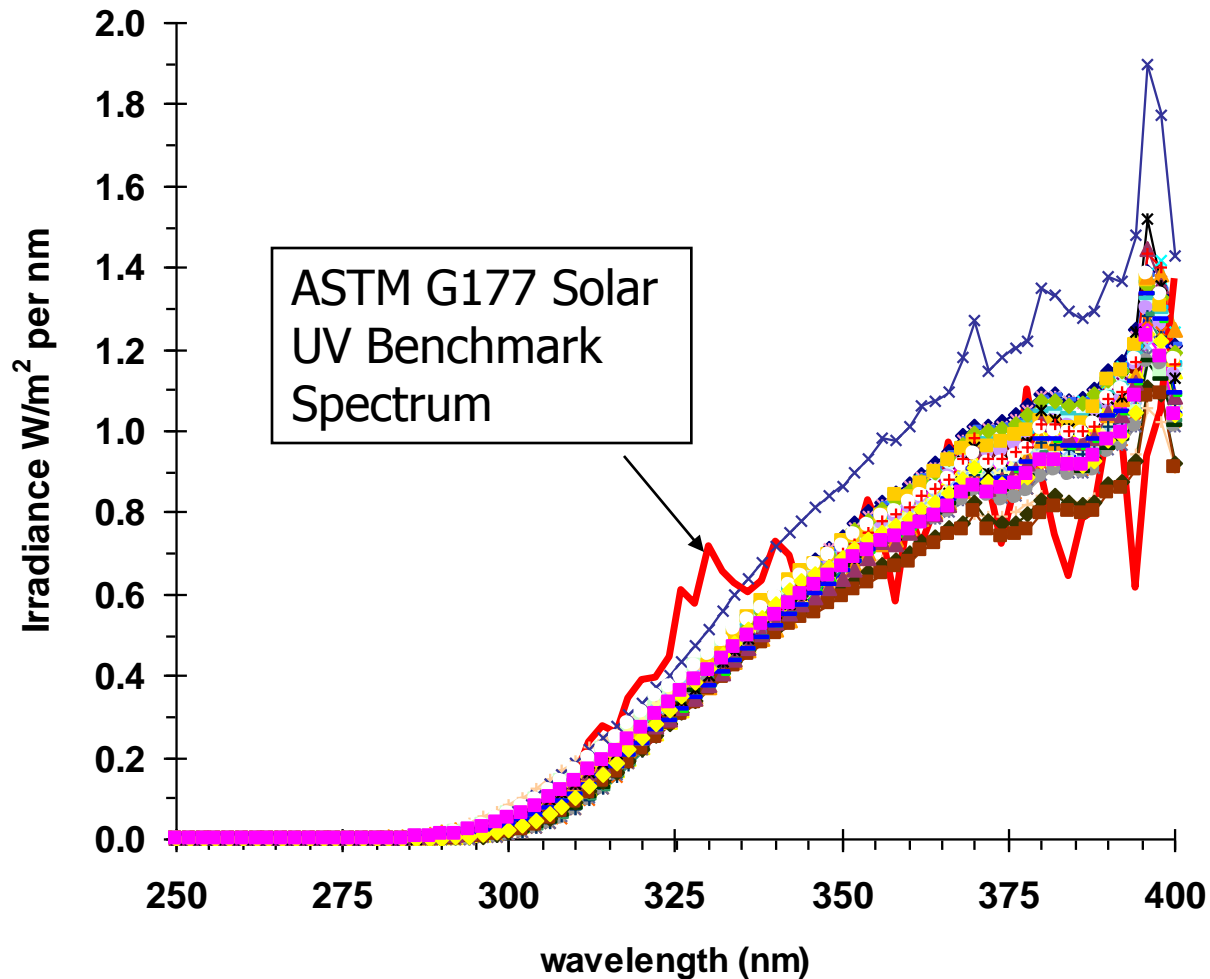

# Xenon-arc with daylight filters compared to benchmark solar UV

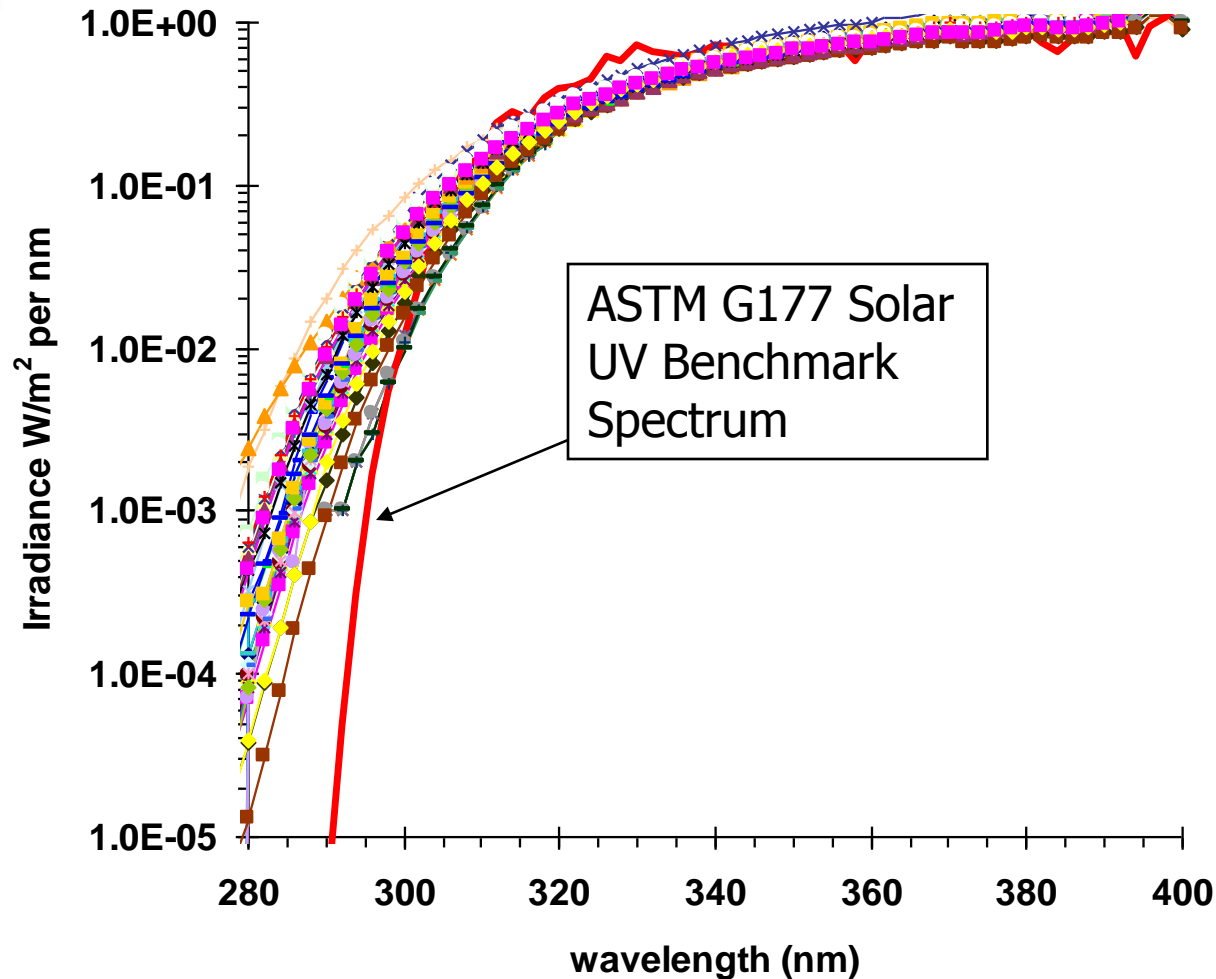

# Selecting a solar spectral benchmark

- ASTM G 177 compared to CIE 85 Table 4

Atmospheric condition	ASTM G 177 benchmark solar spectrum	CIE 85 Table 4 solar spectrum
Ozone (atm-cm)	0.30	0.34
Precipitable water vapor (cm)	0.57	1.42
Altitude (m)	2000	0
Tilt angle	37° facing Equator	0° (horizontal)
Air mass	1.05	1.00
Albedo (ground reflectance)	Light Soil wavelength dependent	Constant at 0.2
Aerosol extinction	Shettle & Fenn Rural (humidity dependent)	Equivalent to Linke Turbidity factor of about 2.8
Aerosol optical thickness at 500 nm	0.05	0.10

# Why is total irradiance in CIE 85 Table 4 higher than G177 benchmark solar?

## ■ Tilt angle

- CIE 85 Table 4 is horizontal
- G 177 is 37° S

## ■ Air mass

- CIE 85 Table 4 is 1.0
- ASTM G 177 is 1.05

air mass	zenith angle	elevation angle
1.0	0.00	90.00
1.05	17.75	72.25

## ■ Bandpass width

- CIE 85 Table 4 are  $\geq 5$  nm or non-uniform
- ASTM G 177 is 1 nm
- Low resolution of CIE 85 Table 4 overestimates integrals
- Range of permissible variation in CIE 85 Table 4 integrals by far exceeds the differences between CIE 85 Table 4 and G 177

# Spectral irradiance comparison CIE 85 table 4\* and ASTM G177

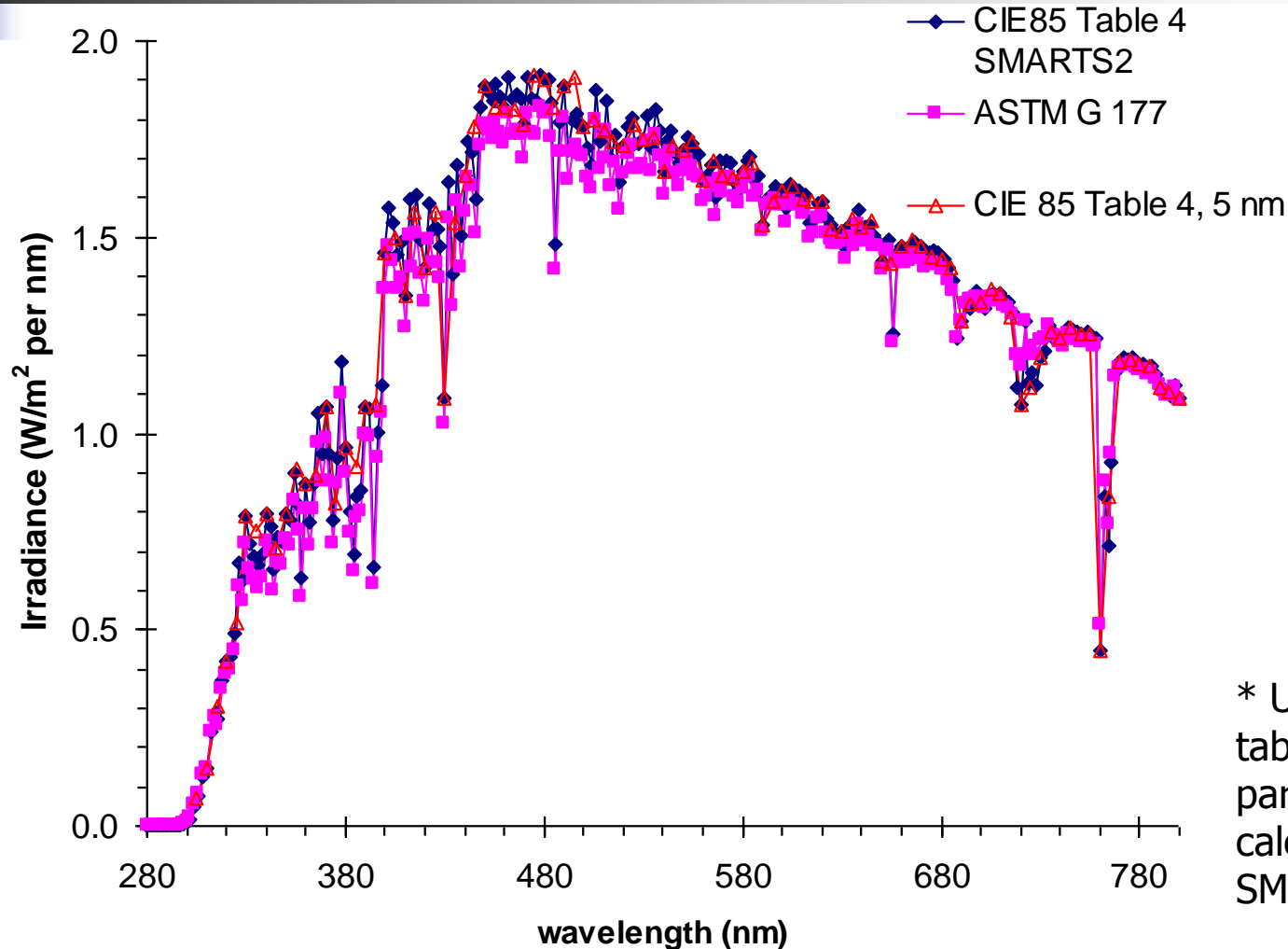

\* Use CIE 85 table 4 input parameters, calculated with SMARTS2, V2.9.2

# Spectral irradiance comparison CIE 85 table 4\* and ASTM G177

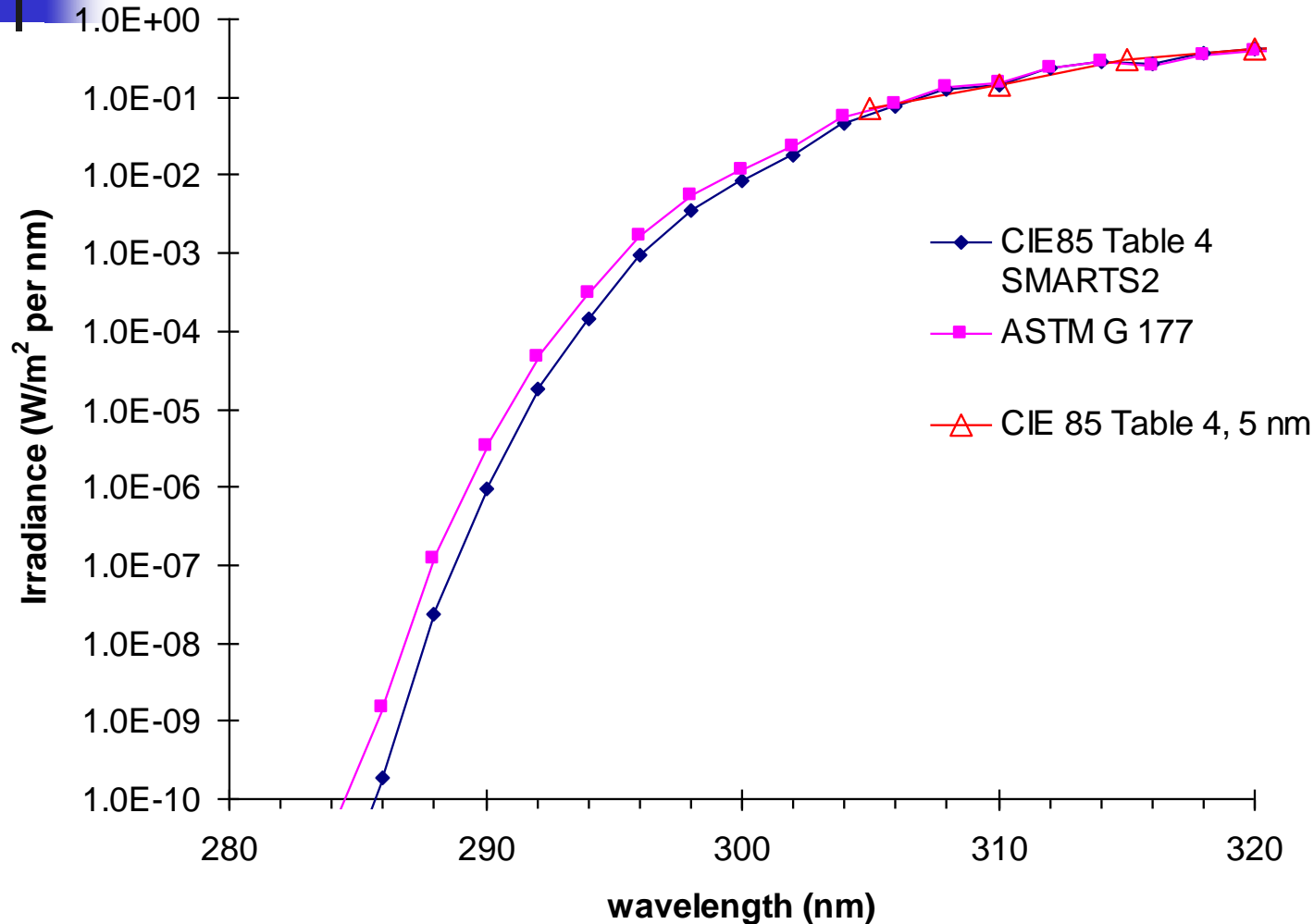

\* Use CIE 85 table 4 input parameters, calculated with SMARTS2, V2.9.2



# Solving an Irradiance Measurement Issue for Controlled Irradiance Exposures

---

- The problem – inconsistent results for measurement of 310 nm irradiance for controlled irradiance fluorescent UVB exposures
  - 310 nm irradiance set points of 0.49 or 0.71 W/m<sup>2</sup>
  - Manufacturer A calibrates their broad band radiometer used to check irradiance and measures correct irradiance in their device with their lamp
  - Manufacturer A checks device from manufacturer B running at the same set point and measures irradiance that is 30% off
- No problem with devices running UVA340 lamps



# Researching the problem

---

- Spectroradiometer intercomparison
  - Both manufacturers plus an interested user
  - Three spectroradiometers
  - Two fluorescent UV devices
    - Each with it's own "calibrator" (reference radiometer)
    - "Calibrator" calibrated using spectroradiometer per ASTM G130
    - Calibration transferred to "on board" radiometers used in the exposure device
  - Two fluorescent UVB313 lamps
    - One from each manufacturer



# Intercomparison results

Lamp	set point wavelength	set point irradiance (W/m <sup>2</sup> )	Manufacture A device, manufacturer A calibration			Manufacture B device, manufacturer B calibration		
			SR1 (manuf. A)	SR2 (manuf. B)	SR3	SR1 (manuf. A)	SR2 (manuf. B)	SR3
UVA340	340 nm	0.89	0.872	0.877	0.856	0.867	0.884	0.866
		1.10	1.074	1.083	1.055	1.066	1.086	1.056
UVB313, manuf. A	310 nm	0.49	0.486	0.468	0.471	0.488	0.466	0.488
		0.71	0.704	0.678	0.674	0.711	0.675	0.704
UVB313, manuf. B	310 nm	0.49	0.502	0.481	0.501	0.486	0.481	0.476
		0.71	0.724	0.699	0.715	0.703	0.695	0.686

- Excellent agreement between spectroradiometers
  - Maximum difference was 4.4%



# Intercomparison results

---

## calibration conditions

---

calibrator	manufacturer A	manufacturer B
device	manufacturer A	manufacturer B
lamp	manufacturer B	manufacturer A
310 nm set point ( $\text{W}/\text{m}^2$ )	0.71	0.71

## measurement conditions

---

calibrator	manufacturer A	manufacturer B
device	manufacturer B	manufacturer A
lamp	manufacturer A	manufacturer B
310 nm set point ( $\text{W}/\text{m}^2$ )	0.71	0.71
measured 310 nm irradiance ( $\text{W}/\text{m}^2$ )	0.64	0.83

- A 30% difference when broad band radiometers are calibrated with one lamp and used to measure the other
- Why?

# UVB313 lamp comparison

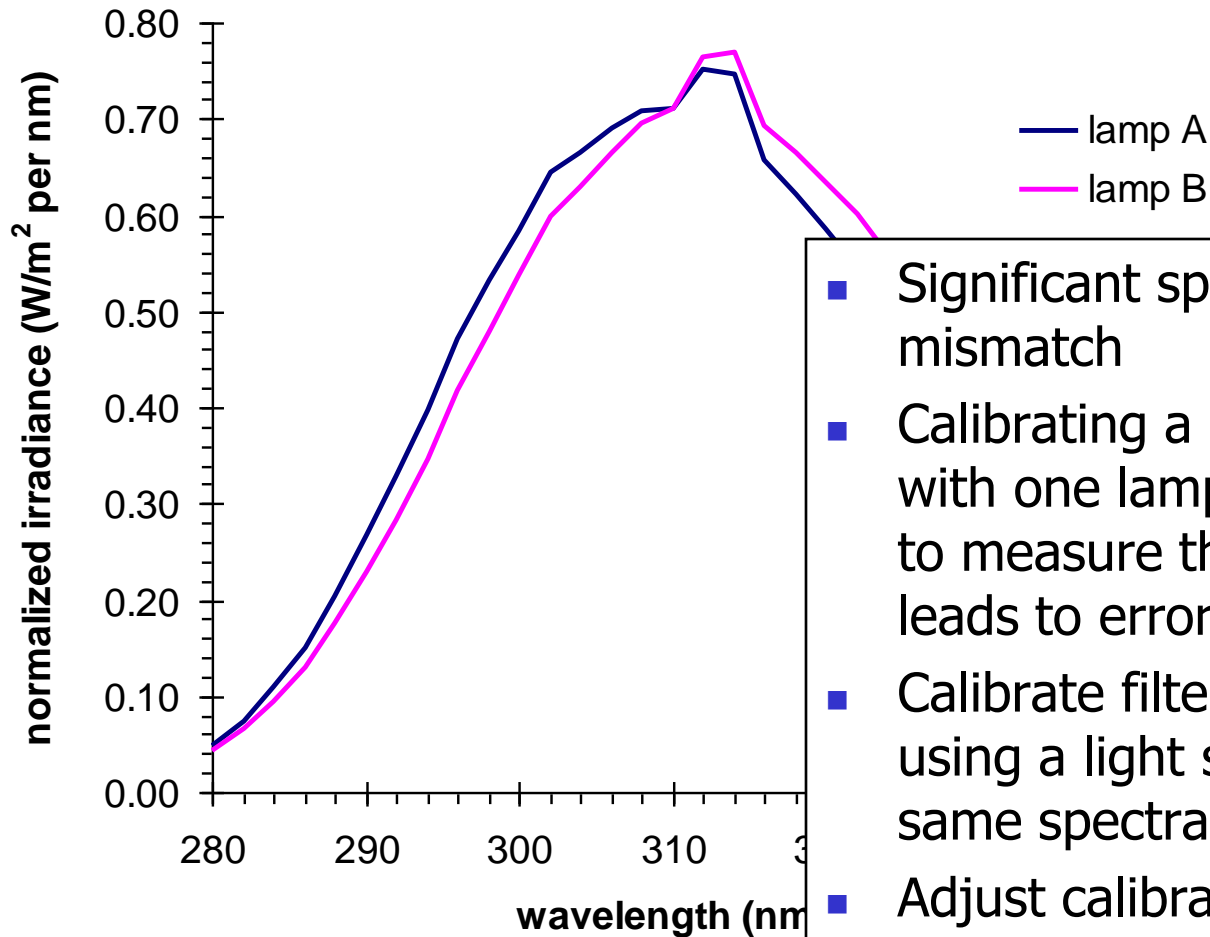

- Significant spectral mismatch
- Calibrating a radiometer with one lamp and using it to measure the other lamp leads to errors
- Calibrate filter radiometers using a light source with the same spectral irradiance
- Adjust calibration for the spectral mismatch

# Spectral Response Function of a UV-B Radiometer vs Solar Radiation

- Integrands from convolution of the spectral response function of a UV-B radiometer with two solar SEDs are disproportionate
- Result is a spectral mismatch error in field measurements
- This makes it difficult to correlate between sites and between a site and accelerated exposures

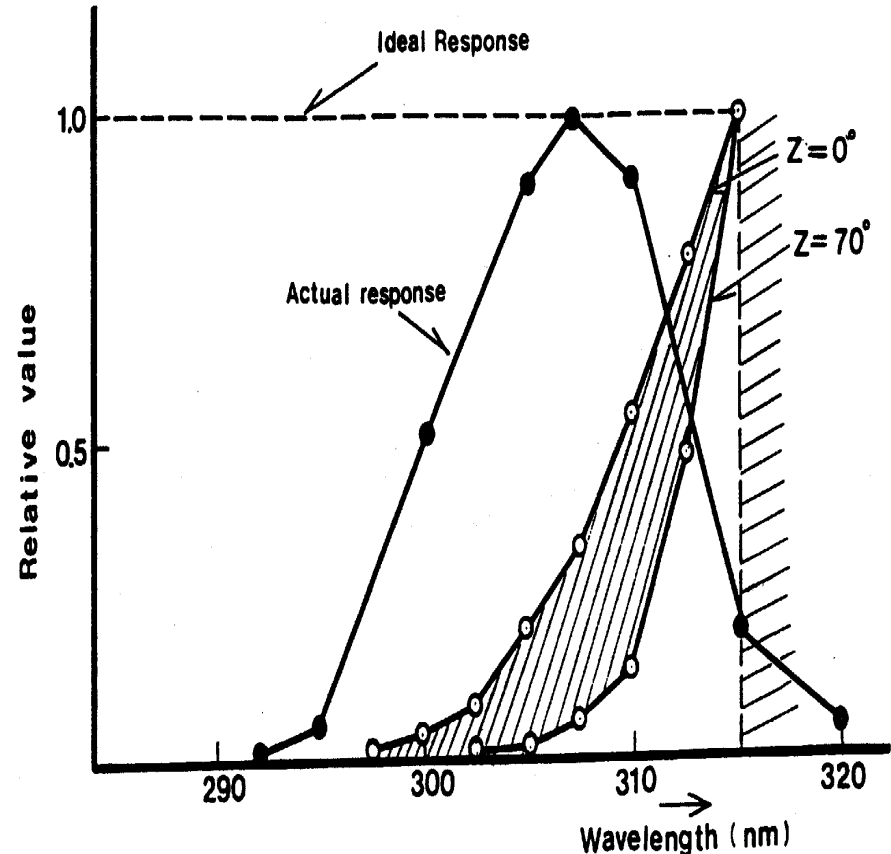

**Magnitude of errors for UV-A measurements are somewhat less**

# Spectral Mismatch Errors are the Major Contributor to Uncertainty in UV-B Measurements

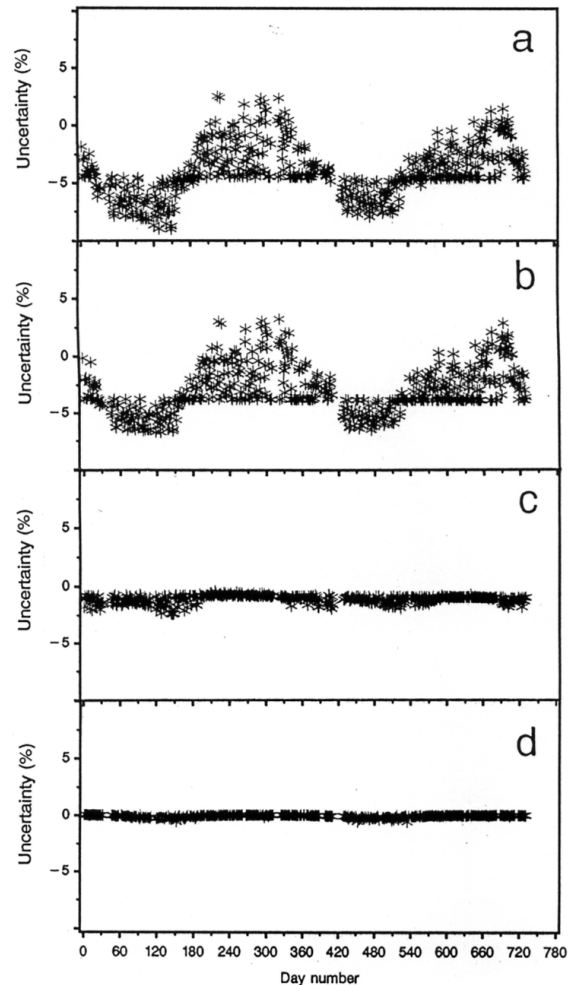

- "a" is total uncertainty
  - "b" is spectral uncertainty
  - "c" is angular uncertainty (cosine error)
  - "d" is temperature effects
- 720 days of data**

Takeshita, Sasaki, Sakata, Miyake & Zerlaut, Eighth Conference on Atmospheric Radiation, 23-28 January 1994, Nashville



# New Issues for Standardization in ASTM G03

---

- A standard is needed that provides a method for accounting for spectral mismatch between the solar spectrum during calibration and the spectra during measurements in the field
- Ultimately, a standard is needed that provides methods for the characterization of pyranometers and UV filter radiometers with respect to:
  - Cosine response (off-angles with respect to direct normal)
  - Temperature response
  - Non-linearity
  - Response time
  - Zero off-set

Don't let this be you...get involved

